

# PARTS CATALOG

## R410A

<b>[Model Name]</b>	<b>[Service Ref.]</b>	
PUHZ-SHW80VHA	PUHZ-SHW80VHA	PUHZ-SHW80VHAR2.UK
	PUHZ-SHW80VHAR3.UK	PUHZ-SHW80VHAR4.UK
PUHZ-SHW112VHA	PUHZ-SHW112VHA	PUHZ-SHW112VHAR2.UK
	PUHZ-SHW112VHAR3.UK	PUHZ-SHW112VHAR4.UK
PUHZ-SHW112YHA	PUHZ-SHW112YHA	PUHZ-SHW112YHAR1
	PUHZ-SHW112YHAR2.UK	PUHZ-SHW112YHAR3.UK
	PUHZ-SHW112YHAR4.UK	
PUHZ-SHW140YHA	PUHZ-SHW140YHA	PUHZ-SHW140YHAR1
	PUHZ-SHW140YHAR2.UK	PUHZ-SHW140YHAR3.UK
	PUHZ-SHW140YHAR4.UK	PUHZ-SHW140YHAR5.UK
<b>Salt proof model</b>		
PUHZ-SHW80VHA-BS	PUHZ-SHW80VHAR2-BS.UK	PUHZ-SHW80VHAR3-BS.UK
	PUHZ-SHW80VHAR4-BS.UK	
PUHZ-SHW112VHA-BS	PUHZ-SHW112VHAR2-BS.UK	PUHZ-SHW112VHAR3-BS.UK
	PUHZ-SHW112VHAR4-BS.UK	
PUHZ-SHW112YHA-BS	PUHZ-SHW112YHAR2-BS.UK	PUHZ-SHW112YHAR3-BS.UK
	PUHZ-SHW112YHAR4-BS.UK	
PUHZ-SHW140YHA-BS	PUHZ-SHW140YHAR2-BS.UK	PUHZ-SHW140YHAR3-BS.UK
	PUHZ-SHW140YHAR4-BS.UK	PUHZ-SHW140YHAR5-BS.UK

Revisions on:  
 • Some descriptions have been modified in REVISED EDITION-H.

OCB526  
 REVISED EDITION-G is void.

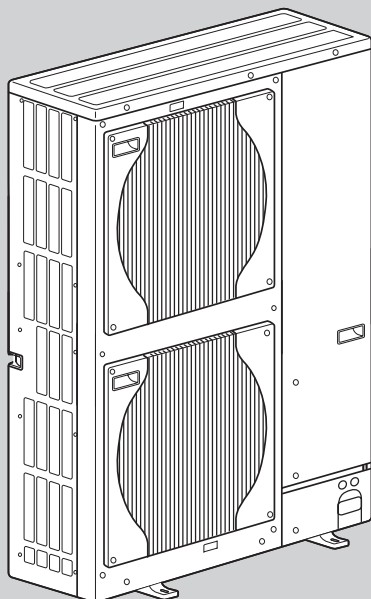

### CONTENTS

1. SERVICE PARTS LIST.....	2
2. OPTIONAL PARTS.....	24

**SERVICE MANUAL (OCH526)**

**FUNCTIONAL AND ELECTRICAL PARTS  
PUHZ-SHW80VHA  
PUHZ-SHW112VHA**

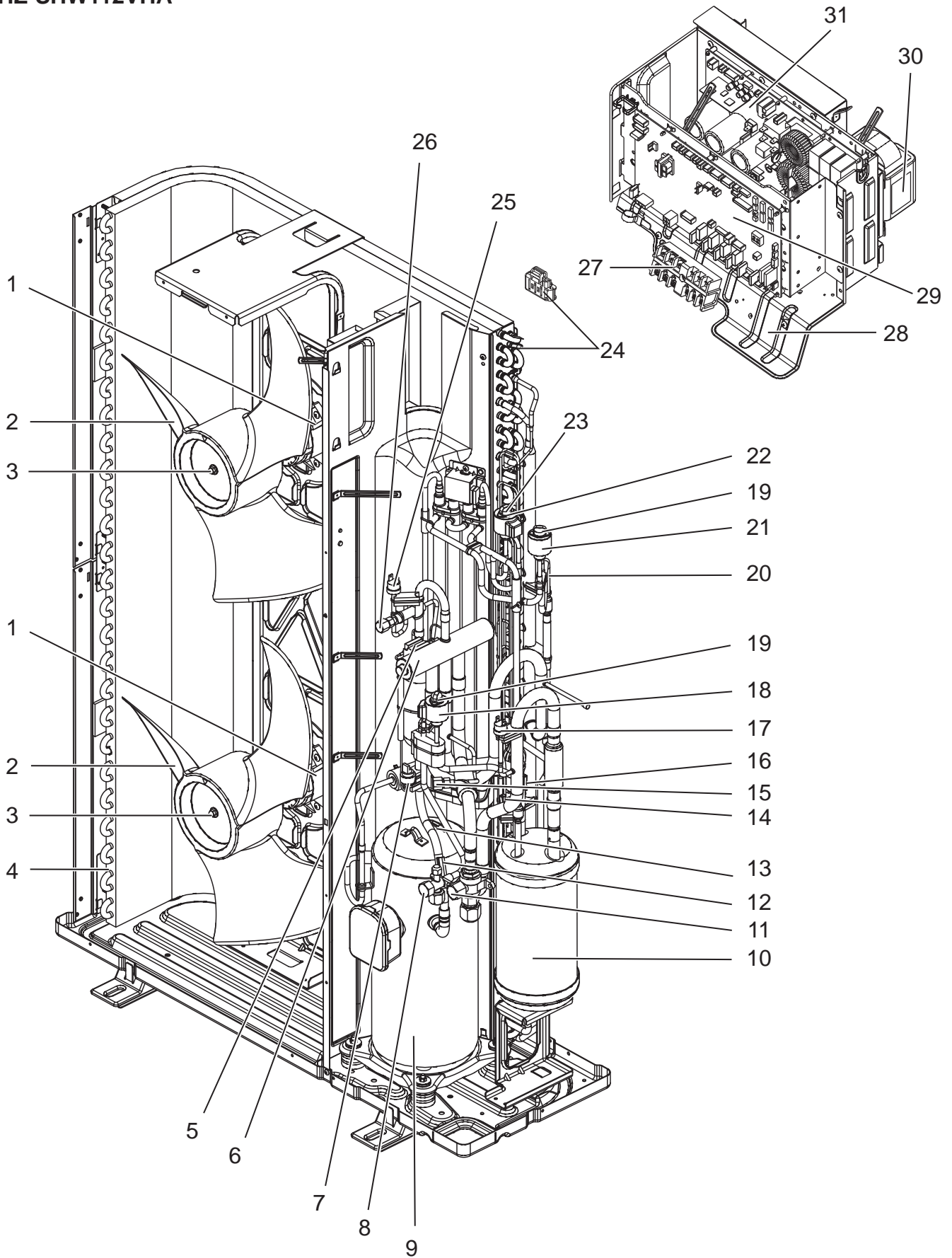

Parts numbers that are circled are not shown in the figure.

No.	Part No.	Part Name	Specification	Q'ty/unit		Remarks (Drawing No.)	Wiring Diagram Symbol
				PUHZ-SHW. VHA			
				80	112		
1	R01 E50 221	FAN MOTOR		2	2		MF1,2
2	R01 E06 115	PROPELLER FAN		2	2		
3	R01 E09 097	NUT		2	2		
4	T7W E70 408	HEAT EXCHANGER		1	1		
5	T7W E41 242	SOLENOID COIL<4-WAY VALVE>		1	1		21S4
6	R01 E15 403	4-WAY VALVE		1	1		
7	R01 E07 208	HIGH PRESSURE SENSOR		1	1		63HS
8	R01 E13 410	STOP VALVE	3/8" (LIQUID)	1	1		
9	T97 422 077	COMPRESSOR	ANB33FJMMT	1	1	Including RUBBER MOUNTS	MC
10	R01 E60 440	POWER RECEIVER		1	1		
11	R01 E12 410	BALL VALVE	5/8" (GAS)	1	1		
12	R01 E22 201	THERMISTOR (DISCHARGE)		1	1		TH4
13	R01 H90 202	THERMISTOR (COMP. SURFACE)		1	1		TH34
14	R01 H00 202	THERMISTOR (LIQUID)		1	1		TH3
15	R01 E17 413	CHARGE PLUG		1	1		
16	R01 H32 202	THERMISTOR (SUCTION)		1	1		TH32
17	R01 E00 209	LOW PRESSURE SWITCH		1	1		63L
18	R01 H08 242	LINEAR EXPANSION VALVE COIL		1	1	Connector:Red	LEV-B
19	T7W E27 401	LINEAR EXPANSION VALVE		2	2	for LEV-A,B	
20	R01 H79 202	THERMISTOR (REF.CHECK)		1	1		TH33
21	R01 H09 242	LINEAR EXPANSION VALVE COIL		1	1	Connector:White	LEV-A
22	R01 H10 242	LINEAR EXPANSION VALVE COIL		1	1	Connector:Blue	LEV-C
23	R01 H22 401	LINEAR EXPANSION VALVE		1	1	for LEV-C	
24	R01 E94 202	THERMISTOR (2-PHASE PIPE, AMBIENT)		1	1		TH6,7
25	R01 E06 208	HIGH PRESSURE SWITCH		1	1		63H
26	R01 E18 413	CHARGE PLUG		1	1		
27	T7W E61 716	TERMINAL BLOCK	6P (L,N,⊕,S1,S2,S3)	1	1		TB1
28	—	ELECTRICAL PARTS BOX		1	1	(BK00B055GA8)	
29	T7W F18 315	CONTROLLER CIRCUIT BOARD		1	1		C.B.
30	R01 E43 259	REACTOR		1	1		DCL
31	R01 A50 353	POWER CIRCUIT BOARD		1	1		P.B.
③②	R01 E14 239	FUSE	250V 6.3A	4	4		F1,2,3,4
③③	R01 E20 254	MAIN SMOOTHING CAPACITOR		1	1		CB

**FUNCTIONAL AND ELECTRICAL PARTS**

**PUHZ-SHW80VHAR2.UK**

**PUHZ-SHW80VHAR3.UK**

**PUHZ-SHW80VHAR2-BS.UK**

**PUHZ-SHW80VHAR3-BS.UK**

**PUHZ-SHW112VHAR2.UK**

**PUHZ-SHW112VHAR3.UK**

**PUHZ-SHW112VHAR2-BS.UK**

**PUHZ-SHW112VHAR3-BS.UK**

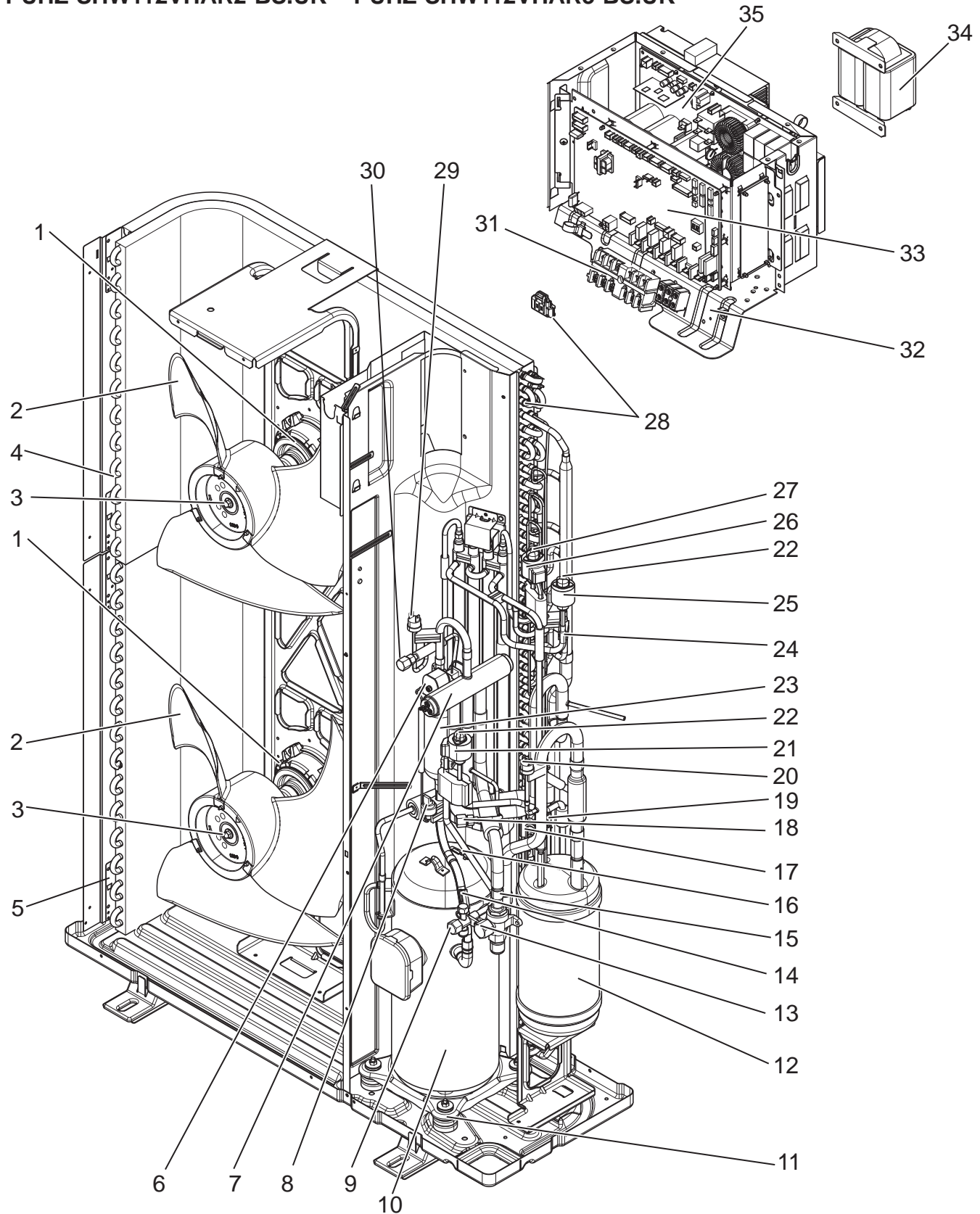

Parts number that is circled is not shown in the figure.

No	Part No.	Part Name	Specification	Q'ty/unit								Remarks (Drawing No.)	Wiring Diagram Symbol
				PUHZ-SHW80VHAR2.UK	PUHZ-SHW80VHAR2-BS.UK	PUHZ-SHW112VHAR2.UK	PUHZ-SHW112VHAR2-BS.UK	PUHZ-SHW80VHAR3.UK	PUHZ-SHW80VHAR3-BS.UK	PUHZ-SHW112VHAR3.UK	PUHZ-SHW112VHAR3-BS.UK		
1	S70 E30 763	FAN MOTOR		2	2	2	2	2	2	2	2		MF1,2
2	S70 E30 115	PROPELLER FAN		2	2	2	2	2	2	2	2		
3	S70 K01 097	NUT		2	2	2	2	2	2	2	2		
4	S70 E55 408	HEAT EXCHANGER (TOP)		1	1	1	1	1	1	1	1		
5	S70 E95 408	HEAT EXCHANGER (UNDER)		1	1	1	1	1	1	1	1		
6	S70 E06 242	SOLENOID COIL <4WAY COIL>		1	1	1	1	1	1	1	1		21S4
7	S70 E05 403	REVERSING VALVE (4-WAY VALVE)		1	1	1	1	1	1	1	1		
8	S70 E11 208H	HIGH PRESSURE SENSOR		1	1	1	1	1	1	1	1		63HS
9	S70 600 418	STOP VALVE (LIQUID)	3/8"	1	1	1	1	1	1	1	1		
10	S70 E50 400	COMPRESSOR	ANB33FJRMT	1	1	1	1	1	1	1	1		MC
11	S70 E02 004	RUBBER MOUNT		4	4	4	4	4	4	4	4		
12	S70 E75 440H	POWER RECEIVER(ACCUMULATOR)		1	1	1	1	1	1	1	1		
13	S70 E06 411	BALL VALVE (GAS)	5/8"	1	1	1	1	1	1	1	1		
14	S70 E61 202	THERMISTOR (DISCHARGE)	D8	1	1	1	1	1	1	1	1		TH4
15	S70 36L 450	STRAINER	#50	1	1	1	1	1	1	1	1		
16	S70 E53 202	THERMISTOR (COMP.SURFACE)		1	1	1	1	1	1	1	1		TH34
17	S70 E58 202	THERMISTOR-H (LIQUID)	1050 XAP	1	1	1	1	1	1	1	1		TH3
18	S70 E02 413	CHARGE PLUG		1	1	1	1	1	1	1	1		
19	S70 E65 202	THERMISTOR (SUCTION)	2/G1150XA	1	1	1	1	1	1	1	1		TH32
20	S70 H20 209	LOW PRESSURE SWITCH		1	1	1	1	1	1	1	1		63L
21	S70 E87 402	LINEAR EXPANSION VALVE COIL	UKV-A211	1	1	1	1	1	1	1	1	Connector: Red	LEV-B
22	S70 E92 401	LINEAR EXPANSION VALVE	UKV-32D135	2	2	2	2	2	2	2	2	FOR LEV-A, B	
23	S70 42H 467	MUFFLER		1	1	1	1	1	1	1	1		
24	S70 E63 202	THERMISTOR	1000-3P	1	1	1	1	1	1	1	1		TH33
25	S70 E88 402	LINEAR EXPANSION VALVE COIL	UKV-A212	1	1	1	1	1	1	1	1	Connector: White	LEV-A
26	S70 E99 402	LINEAR EXPANSION VALVE COIL	UKV	1	1	1	1	1	1	1	1	Connector: Blue	LEV-C
27	S70 E80 401	EXPANSION VALVE	UKV-18D35	1	1	1	1	1	1	1	1	FOR LEV-C	
28	S70 E31 202	THERMISTOR-W (OUTDOOR, 2-PHASE PIPE, AMBIENT)	850/1050	1	1	1	1	1	1	1	1		TH6,7
29	S70 E10 208H	HIGH PRESSURE SWITCH	OFF 4.14MPa	1	1	1	1	1	1	1	1		63H
30	S70 E03 413	CHARGE PLUG		1	1	1	1	1	1	1	1		
31	S70 C20 515	TERMINAL BLOCK	6P (L,N,0,S1,S2,S3)	1	1	1	1	1	1	1	1		TB1
32	S70 R84 316	COMPLETE CONTROL BOX ASSY		1	1			1	1				
	S70 R81 316	COMPLETE CONTROL BOX ASSY				1	1			1	1		
33	S70 E70 315	CONTROLLER BOARD		1	1	1	1						C.B
	S70 E75 315	CONTROLLER BOARD						1	1	1	1		C.B
34	S70 K04 259	REACTOR (DCL)		1	1	1	1	1	1	1	1		DCL
35	S70 E30 313	POWER BOARD		1	1	1	1	1	1	1	1		P.B
36	S70 E05 255	MAIN SMOOTHING CAPACITOR		1	1	1	1	1	1	1	1		CB

# FUNCTIONAL AND ELECTRICAL PARTS

PUHZ-SHW80VHAR4.UK

PUHZ-SHW112VHAR4.UK

PUHZ-SHW80VHAR4-BS.UK

PUHZ-SHW112VHAR4-BS.UK

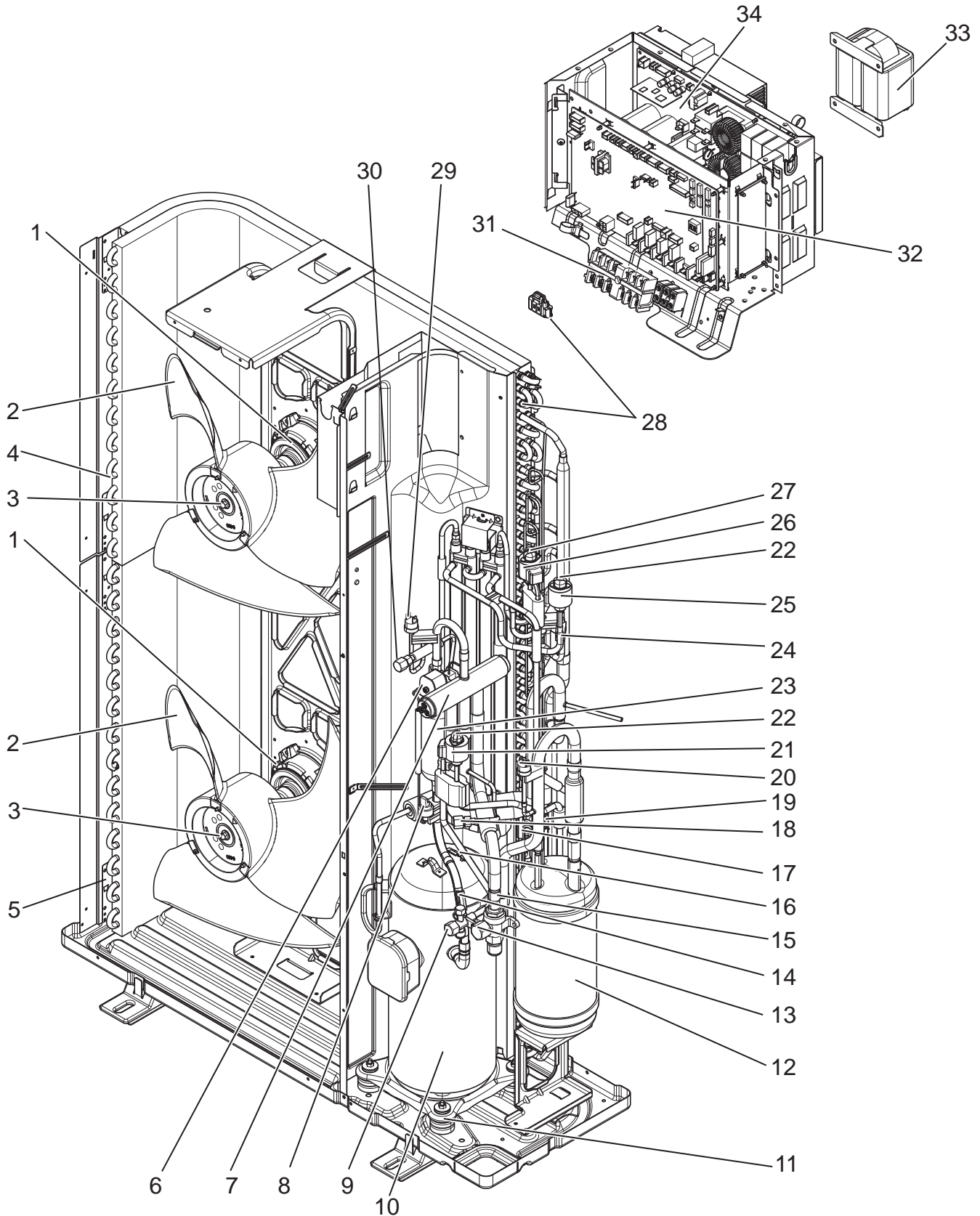

No	Part No.	Part Name	Specification	Q'ty/unit				Remarks (Drawing No.)	Wiring Diagram Symbol
				PUHZ-SHW80VHAR4.UK	PUHZ-SHW80VHAR4-BS.UK	PUHZ-SHW112VHAR4.UK	PUHZ-SHW112VHAR4-BS.UK		
1	S70 E35 763	FAN MOTOR		2	2	2	2		MF1,2
2	S70 E30 115	PROPELLER FAN		2	2	2	2		
3	S70 K01 097	NUT		2	2	2	2		
4	S70 E55 408	HEAT EXCHANGER (TOP)		1	1	1	1		
5	S70 E95 408	HEAT EXCHANGER (UNDER)		1	1	1	1		
6	S70 E06 242	SOLENOID COIL <4WAY COIL>		1	1	1	1		21S4
7	S70 E05 403	REVERSING VALVE (4-WAY VALVE)		1	1	1	1		
8	S70 E11 208H	HIGH PRESSURE SENSOR		1	1	1	1		63HS
9	S70 600 418	STOP VALVE (LIQUID)	3/8"	1	1	1	1		
10	S70 E50 400	COMPRESSOR	ANB33FJRMT	1	1	1	1		MC
11	S70 E02 004	RUBBER MOUNT		4	4	4	4		
12	S70 E75 440H	POWER RECEIVER (ACCUMULATOR)		1	1	1	1		
13	S70 E06 411	BALL VALVE (GAS)	5/8"	1	1	1	1		
14	S70 E61 202	THERMISTOR (DISCHARGE)	D8	1	1	1	1		TH4
15	S70 36L 450	STRAINER	#50	1	1	1	1		
16	S70 E53 202	THERMISTOR (COMP. SURFACE)		1	1	1	1		TH34
17	S70 E58 202	THERMISTOR-H (LIQUID)	1050 XAP	1	1	1	1		TH3
18	S70 E02 413	CHARGE PLUG		1	1	1	1		
19	S70 E65 202	THERMISTOR (SUCTION)	2/G1150XA	1	1	1	1		TH32
20	S70 H20 209	LOW PRESSURE SWITCH		1	1	1	1		63L
21	S70 E87 402	LINEAR EXPANSION VALVE COIL	UKV-A211	1	1	1	1	Connector: Red	LEV-B
22	S70 E92 401	LINEAR EXPANSION VALVE	UKV-32D135	2	2	2	2	FOR LEV-A, B	
23	S70 42H 467	MUFFLER		1	1	1	1		
24	S70 E63 202	THERMISTOR	1000-3P	1	1	1	1		TH33
25	S70 E88 402	LINEAR EXPANSION VALVE COIL	UKV-A212	1	1	1	1	Connector: White	LEV-A
26	S70 E99 402	LINEAR EXPANSION VALVE COIL	UKV	1	1	1	1	Connector: Blue	LEV-C
27	S70 E80 401	EXPANSION VALVE	UKV-18D35	1	1	1	1	FOR LEV-C	
28	S70 E31 202	THERMISTOR-W (OUTDOOR, 2-PHASE PIPE, AMBIENT)	850/1050	1	1	1	1		TH6,7
29	S70 E10 208H	HIGH PRESSURE SWITCH	OFF 4.14MPa	1	1	1	1		63H
30	S70 E03 413	CHARGE PLUG		1	1	1	1		
31	S70 C20 515	TERMINAL BLOCK	6P (L,N,⊕,S1,S2,S3)	1	1	1	1		TB1
32	S70 E56 315H	CONTROLLER BOARD		1	1	1	1		C.B
33	S70 K04 259	REACTOR (DCL)		1	1	1	1		DCL
34	S70 E31 313	POWER BOARD		1	1	1	1		P.B

**FUNCTIONAL AND ELECTRICAL PARTS**  
**PUHZ-SHW112YHA**  
**PUHZ-SHW140YHA**

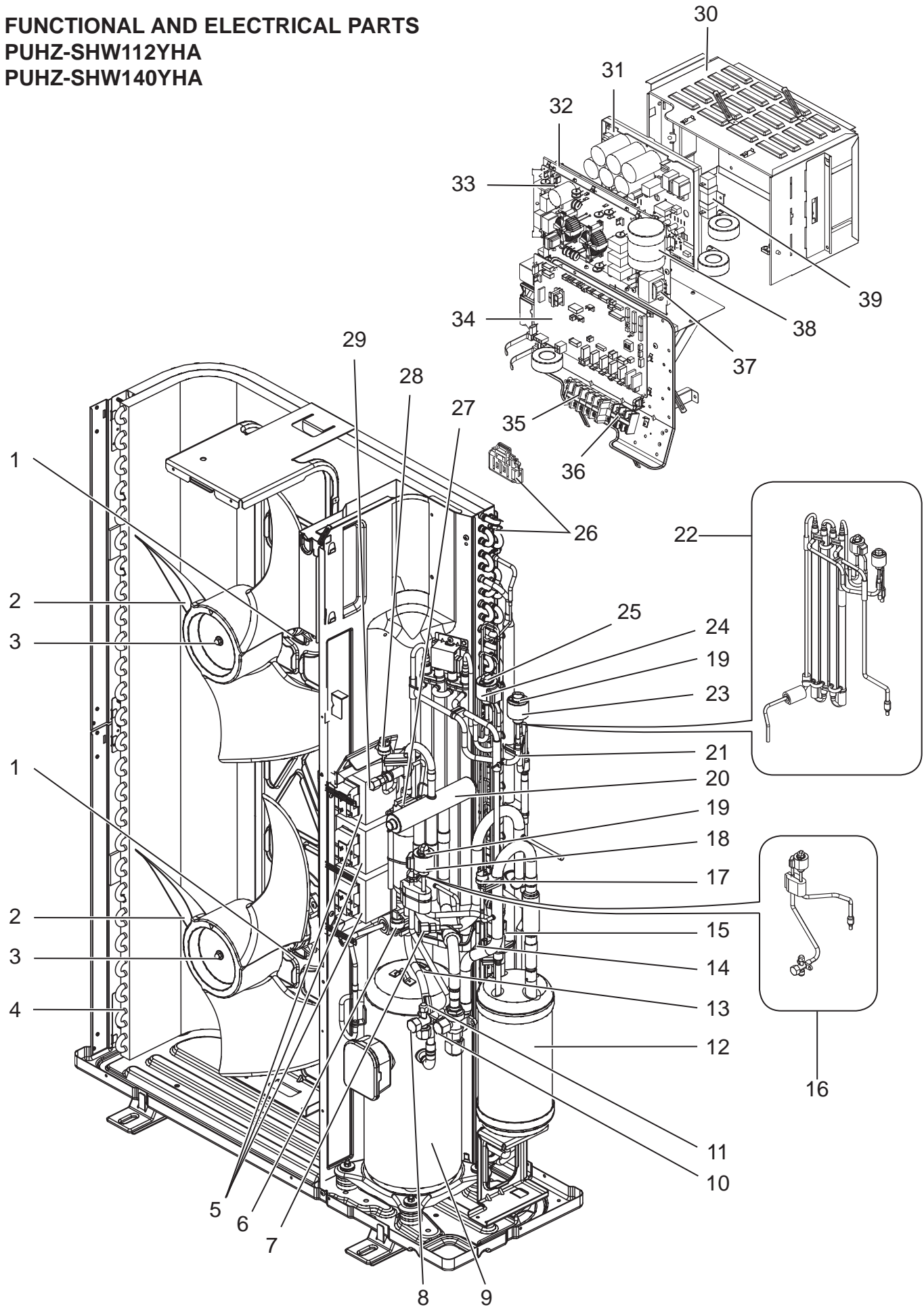



Parts numbers that are circled are not shown in the figure.

No.	Part No.	Part Name	Specification	Q'ty/unit		Remarks (Drawing No.)	Wiring Diagram Symbol
				PUHZ-SHW-YHA			
				112	140		
1	R01 E50 221	FAN MOTOR		2	2		MF1,2
2	R01 E06 115	PROPELLER FAN		2	2		
3	R01 E09 097	NUT		2	2		
4	T7W E70 408	HEAT EXCHANGER		1	1		
5	T7W E12 259	REACTOR		3	3		ACL1,2,3
6	R01 E07 208	HIGH PRESSURE SENSOR		1	1		63HS
7	R01 E17 413	CHARGE PLUG		1	1		
8	R01 E13 410	STOP VALVE	3/8" (LIQUID)	1	1		
9	T97 421 077	COMPRESSOR	ANB33FJLMT	1	1	Including RUBBER MOUNTS	MC
10	R01 E12 410	BALL VALVE	5/8" (GAS)	1	1		
11	R01 E22 201	THERMISTOR (DISCHARGE)		1	1		TH4
12	R01 E60 440	POWER RECEIVER		1	1		
13	R01 H90 202	THERMISTOR (COMP. SURFACE)		1	1		TH34
14	R01 H00 202	THERMISTOR (LIQUID)		1	1		TH3
15	R01 H17 202	THERMISTOR (SUCTION)		1	1		TH32
16	T7W E38 401	LEV ASSY		1	1	Including coil for LEV-B & STV	
17	R01 E00 209	LOW PRESSURE SWITCH		1	1		63L
18	R01 H08 242	LINEAR EXPANSION VALVE COIL		1	1	Connector:Red	LEV-B
19	T7W E27 401	LINEAR EXPANSION VALVE		2	2	for LEV-A,B	
20	R01 E15 403	4-WAY VALVE		1	1		
21	R01 H79 202	THERMISTOR (REF. CHECK)		1	1		TH33
22	T7W E39 401	LEV ASSY HIC		1	1	Including coil for LEV-A,C	
23	R01 H09 242	LINEAR EXPANSION VALVE COIL		1	1	Connector:White	LEV-A
24	R01 H10 242	LINEAR EXPANSION VALVE COIL		1	1	Connector:Blue	LEV-C
25	R01 H22 401	LINEAR EXPANSION VALVE		1	1	for LEV-C	
26	R01 H01 202	THERMISTOR (2-PHASE PIPE, AMBIENT)		1	1		TH6,7
27	T7W E39 242	SOLENOID COIL <4-WAY VALVE>		1	1		21S4
28	R01 E06 208	HIGH PRESSURE SWITCH		1	1		63H
29	R01 E18 413	CHARGE PLUG		1	1		
30	—	ELECTRICAL PARTS BOX		1	1	(BK00C410G17)	
31	T7W A10 323	POWER CIRCUIT BOARD		1	1		P.B.
32	T7W E75 310	CONVERTER CIRCUIT BOARD		1	1		CONV.B.
33	T7W E28 346	NOISE FILTER CIRCUIT BOARD		1	1		N.F.
34	T7W F19 315	CONTROLLER CIRCUIT BOARD		1	1		C.B.
35	T7W E30 716	TERMINAL BLOCK	5P (L1,L2,L3,N,⊕)	1	1		TB1
36	R01 E19 246	TERMINAL BLOCK	3P (S1,S2,S3)	1	1		TB2
37	R01 E31 259	REACTOR		1	1		ACL4
38	T7W E10 254	CAPACITOR		1	1		CK
39	R01 E10 233	RESISTOR		1	1		RS
④0	R01 E14 239	FUSE	250V 6.3A	4	4		F1,2,3,4
④1	R01 E14 510	LEAD ASSY COMP		1	1		
④2	R01 H93 202	THERMISTOR (HEAT SINK)		1	1		TH8

**FUNCTIONAL AND ELECTRICAL PARTS**  
**PUHZ-SHW112YHAR1**  
**PUHZ-SHW140YHAR1**

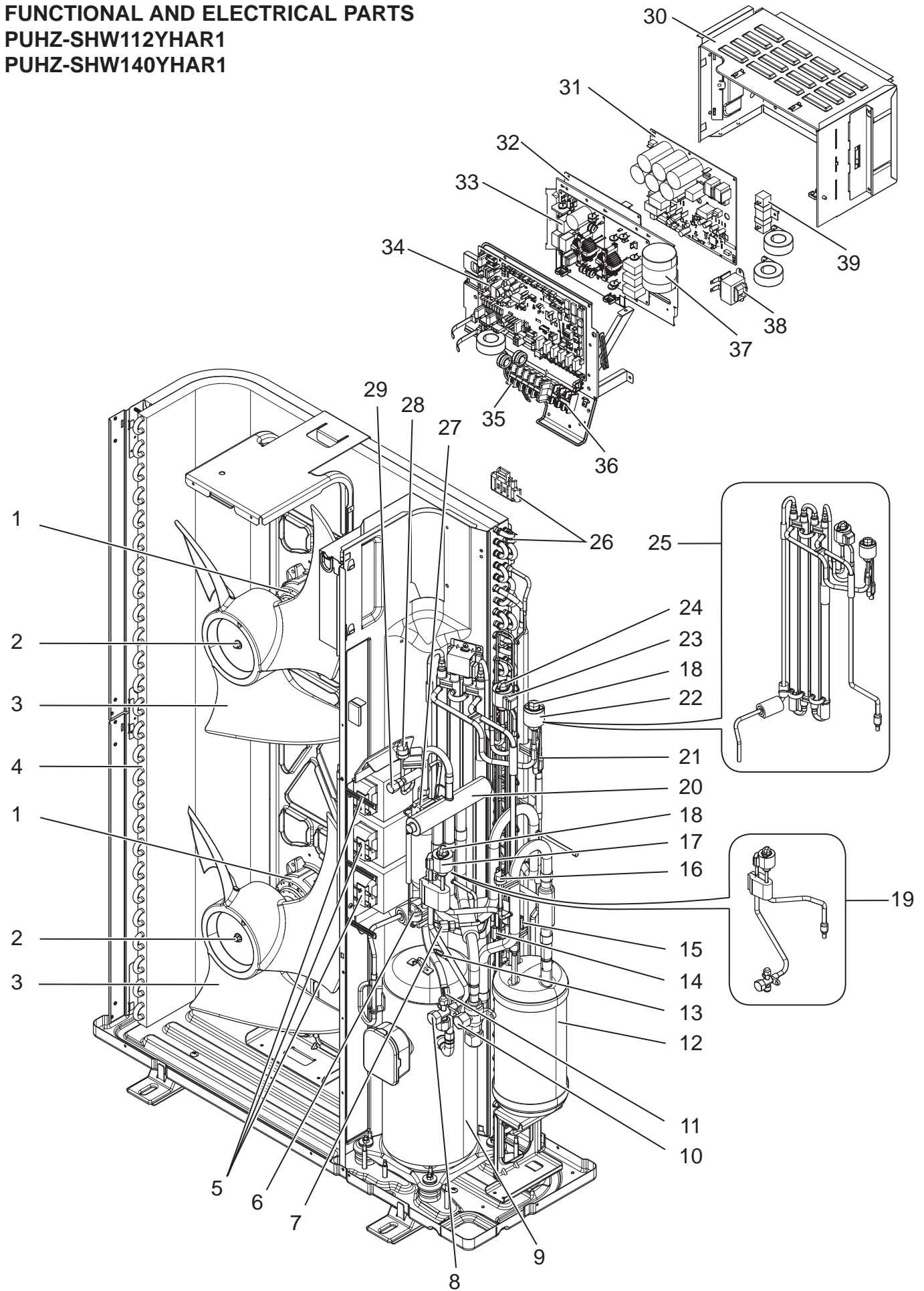

Parts numbers that are circled are not shown in the figure.

No.	Part No.	Part Name	Specification	Q'ty/unit		Remarks (Drawing No.)	Wiring Diagram Symbol
				PUHZ-SHW-YHAR1			
				112	140		
1	R01 E50 221	FAN MOTOR		2	2		MF1,2
2	R01 E09 097	NUT		2	2		
3	R01 E06 115	PROPELLER FAN		2	2		
4	T7W E70 408	HEAT EXCHANGER		1	1		
5	T7W E12 259	REACTOR		3	3		ACL1,2,3
6	R01 E07 208	HIGH PRESSURE SENSOR		1	1		63HS
7	R01 E17 413	CHARGE PLUG		1	1		
8	R01 E13 410	STOP VALVE	3/8" (LIQUID)	1	1		
9	T97 421 077	COMPRESSOR	ANB33FJLMT	1	1	Including RUBBER MOUNTS	MC
10	R01 E12 410	BALL VALVE	5/8" (GAS)	1	1		
11	R01 E22 201	THERMISTOR (DISCHARGE)		1	1		TH4
12	R01 E60 440	POWER RECEIVER		1	1		
13	R01 H90 202	THERMISTOR (COMP. SURFACE)		1	1		TH34
14	R01 H00 202	THERMISTOR (LIQUID)		1	1		TH3
15	R01 H17 202	THERMISTOR (SUCTION)		1	1		TH32
16	R01 E00 209	LOW PRESSURE SWITCH		1	1		63L
17	R01 H08 242	LINEAR EXPANSION VALVE COIL		1	1	Connector:Red	LEV-B
18	T7W E27 401	LINEAR EXPANSION VALVE		2	2	for LEV-A,B	
19	T7W E38 401	LEV ASSY		1	1	Including coil for LEV-B & STV	
20	R01 E15 403	4-WAY VALVE		1	1		
21	R01 H79 202	THERMISTOR (REF. CHECK)		1	1		TH33
22	R01 H09 242	LINEAR EXPANSION VALVE COIL		1	1	Connector:White	LEV-A
23	R01 H10 242	LINEAR EXPANSION VALVE COIL		1	1	Connector:Blue	LEV-C
24	R01 H22 401	LINEAR EXPANSION VALVE		1	1	for LEV-C	
25	T7W E39 401	LEV ASSY HIC		1	1	Including coil for LEV-A,C	
26	R01 H01 202	THERMISTOR (2-PHASE PIPE, AMBIENT)		1	1		TH6,7
27	T7W E39 242	SOLENOID COIL <4-WAY VALVE>		1	1		21S4
28	R01 E06 208	HIGH PRESSURE SWITCH		1	1		63H
29	R01 E18 413	CHARGE PLUG		1	1		
30	—	ELECTRICAL PARTS BOX		1	1	(BK00C410G17)	
31	T7W A20 323	POWER CIRCUIT BOARD		1	1		P.B.
32	T7W E75 310	CONVERTER CIRCUIT BOARD		1	1		CONV.B.
33	T7W E28 346	NOISE FILTER CIRCUIT BOARD		1	1		N.F.
34	T7W F19 315	CONTROLLER CIRCUIT BOARD		1	1		C.B.
35	T7W E30 716	TERMINAL BLOCK	5P (L1,L2,L3,N,⊕)	1	1		TB1
36	R01 E19 246	TERMINAL BLOCK	3P (S1,S2,S3)	1	1		TB2
37	T7W E10 254	CAPACITOR		1	1		CK
38	R01 E31 259	REACTOR		1	1		ACL4
39	R01 E10 233	RESISTOR		1	1		RS
④0	R01 E14 510	LEAD ASSY COMP		1	1		
④1	R01 E14 239	FUSE	250V 6.3A	4	4		F1,2,3,4
④2	R01 H93 202	THERMISTOR (HEAT SINK)		1	1		TH8

**FUNCTIONAL AND ELECTRICAL PARTS**

**PUHZ-SHW112YHAR2.UK  
PUHZ-SHW112YHAR2-BS.UK  
PUHZ-SHW140YHAR2.UK  
PUHZ-SHW140YHAR2-BS.UK**

**PUHZ-SHW112YHAR3.UK  
PUHZ-SHW112YHAR3-BS.UK  
PUHZ-SHW140YHAR3.UK  
PUHZ-SHW140YHAR3-BS.UK**

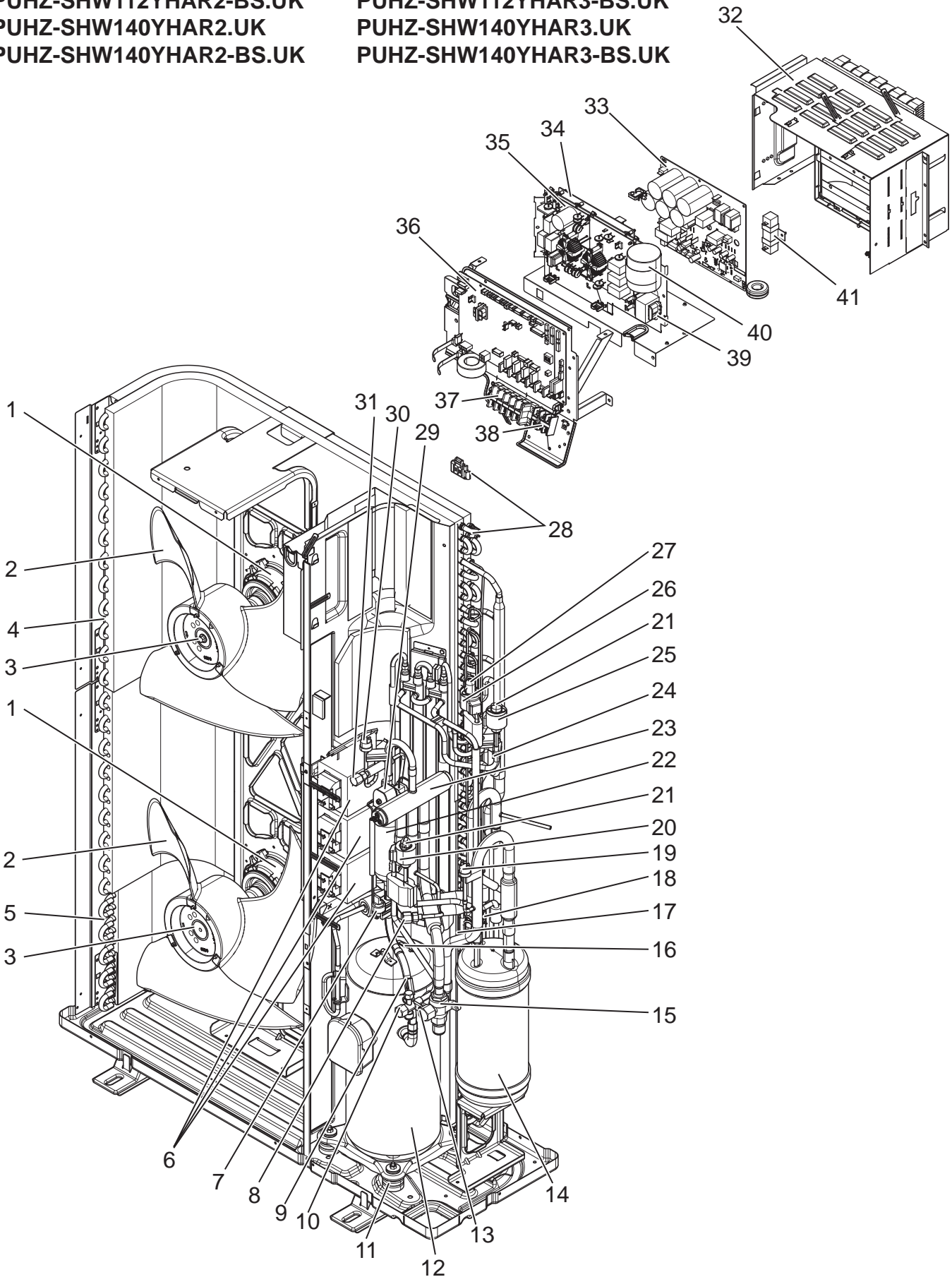

Parts number that is circled is not shown in the figure.

No.	Part No.	Part Name	Specification	Q'ty/unit								Remarks (Drawing No.)	Wiring Diagram Symbol
				PUHZ-SHW112YHAR2.UK	PUHZ-SHW112YHAR2-BS.UK	PUHZ-SHW140YHAR2.UK	PUHZ-SHW140YHAR2-BS.UK	PUHZ-SHW112YHAR3.UK	PUHZ-SHW112YHAR3-BS.UK	PUHZ-SHW140YHAR3.UK	PUHZ-SHW140YHAR3-BS.UK		
1	S70 E30 763	FAN MOTOR		2	2	2	2	2	2	2	2		MF1,2
2	S70 E30 115	PROPELLER FAN		2	2	2	2	2	2	2	2		
3	S70 K01 097	NUT		2	2	2	2	2	2	2	2		
4	S70 E55 408	HEAT EXCHANGER (TOP)		1	1	1	1	1	1	1	1		
5	S70 E95 408	HEAT EXCHANGER (UNDER)		1	1	1	1	1	1	1	1		
6	S70 K80 259	REACTOR		3	3	3	3	3	3	3	3		ACL1,2,3
7	S70 E11 208H	HIGH PRESSURE SENSOR		1	1	1	1	1	1	1	1		63HS
8	S70 E02 413	CHARGE PLUG		1	1	1	1	1	1	1	1		
9	S70 E62 202	THERMISTOR (DISCHARGE)	D8	1	1	1	1	1	1	1	1		TH4
10	S70 600 418	STOP VALVE (LIQUID)	3/8"	1	1	1	1	1	1	1	1		
11	S70 E02 004	RUBBER MOUNT		4	4	4	4	4	4	4	4		
12	S70 E60 400	COMPRESSOR	ANB33FJQMT	1	1	1	1	1	1	1	1		MC
13	S70 E06 411	BALL VALVE (GAS)	5/8"	1	1	1	1	1	1	1	1		
14	S70 E75 440H	POWER RECEIVER (ACCUMULATOR)		1	1	1	1	1	1	1	1		
15	S70 36L 450	STRAINER	#50	1	1	1	1	1	1	1	1		
16	S70 E54 202	THERMISTOR (COMP.SURFACE)		1	1	1	1	1	1	1	1		TH34
17	S70 E37 202	THERMISTOR-H(LIQUID)	1150 XA	1	1	1	1	1	1	1	1		TH3
18	S70 E66 202	THERMISTOR(SUCTION)	2/G950XA	1	1	1	1	1	1	1	1		TH32
19	S70 H20 209	LOW PRESSURE SWITCH		1	1	1	1	1	1	1	1		63L
20	S70 E87 402	LINEAR EXPANSION VALVE COIL	UKV-A211	1	1	1	1	1	1	1	1	Connector: Red	LEV-B
21	S70 E92 401	LINEAR EXPANSION VALVE	UKV-32D135	2	2	2	2	2	2	2	2	FOR LEV-A,B	
22	S70 42H 467	MUFFLER		1	1	1	1	1	1	1	1		
23	S70 E05 403	REVERSING VALVE (4-WAY VALVE)		1	1	1	1	1	1	1	1		
24	S70 E64 202	THERMISTOR	900-3P	1	1	1	1	1	1	1	1		TH33
25	S70 E88 402	LINEAR EXPANSION VALVE COIL	UKV-A212	1	1	1	1	1	1	1	1	Connector: White	LEV-A
26	S70 E99 402	LINEAR EXPANSION VALVE COIL	UKV	1	1	1	1	1	1	1	1	Connector: Blue	LEV-C
27	S70 E80 401	EXPANSION VALVE	UKV-18D35	1	1	1	1	1	1	1	1	FOR LEV-C	
28	S70 E60 202	THERMISTOR-W (OUTDOOR,2-PHASE PIPE, AMBIENT)		1	1	1	1	1	1	1	1		TH6,7
29	S70 E08 242	SOLENOID COIL <4WAY COIL>		1	1	1	1	1	1	1	1		21S4
30	S70 E10 208H	HIGH PRESSURE SWITCH	OFF 4.14MPa	1	1	1	1	1	1	1	1		63H
31	S70 E03 413	CHARGE PLUG		1	1	1	1	1	1	1	1		
32	S70 R82 316	COMPLETE CONTROL BOX ASSY		1	1			1	1				
	S70 R83 316	COMPLETE CONTROL BOX ASSY				1	1			1	1		
33	S70 E90 313	POWER BOARD		1	1	1	1	1	1	1	1		P.B
34	S70 E15 313	CONVERTOR BOARD		1	1	1	1	1	1	1	1		CONV.B
35	S70 E50 346	NOISE FILTER BOARD		1	1	1	1	1	1	1	1		N.F
36	S70 E80 315	CONTROLLER BOARD		1	1	1	1						C.B
	S70 E85 315	CONTROLLER BOARD						1	1	1	1		C.B
37	S70 E09 716	TERMINAL BED	5P (L1, L2, L3,N, E)	1	1	1	1	1	1	1	1		TB1
38	S70 E08 716	TERMINAL BED	3P (S1, S2, S3)	1	1	1	1	1	1	1	1		TB2
39	S70 K90 259	REACTOR		1	1	1	1	1	1	1	1		ACL4
40	S70 E71 255	CAPACITOR		1	1	1	1	1	1	1	1		CK
41	S70 E20 234	RESISTOR		1	1	1	1	1	1	1	1		RS
④2	S70 E55 202	THERMISTOR (HEAT SINK)		1	1	1	1	1	1	1	1		TH8

**FUNCTIONAL AND ELECTRICAL PARTS**

**PUHZ-SHW112YHAR4.UK**

**PUHZ-SHW140YHAR4.UK**

**PUHZ-SHW140YHAR5.UK**

**PUHZ-SHW112YHAR4-BS.UK**

**PUHZ-SHW140YHAR4-BS.UK**

**PUHZ-SHW140YHAR5-BS.UK**

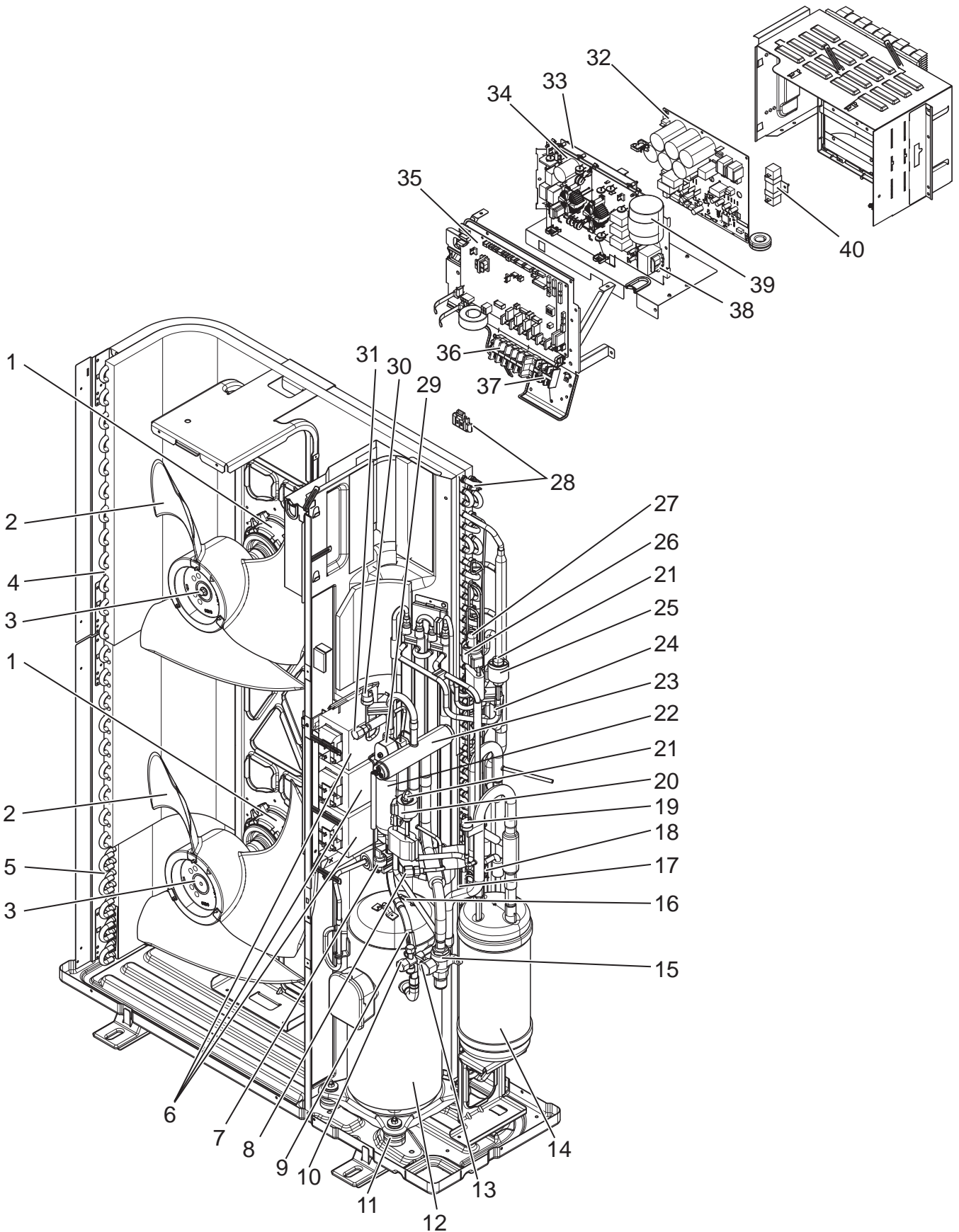

Parts number that is circled is not shown in the figure.

No.	Part No.	Part Name	Specification	Q'ty/unit						Remarks (Drawing No.)	Wiring Diagram Symbol
				PUHZ-SHW112YHAR4.UK	PUHZ-SHW112YHAR4-BS.UK	PUHZ-SHW140YHAR4.UK	PUHZ-SHW140YHAR4-BS.UK	PUHZ-SHW140YHAR5.UK	PUHZ-SHW140YHAR5-BS.UK		
1	S70 E35 763	FAN MOTOR		2	2	2	2	2	2		MF1,2
2	S70 E30 115	PROPELLER FAN		2	2	2	2	2	2		
3	S70 K01 097	NUT		2	2	2	2	2	2		
4	S70 E55 408	HEAT EXCHANGER (TOP)		1	1	1	1	1	1		
5	S70 E95 408	HEAT EXCHANGER (UNDER)		1	1	1	1	1	1		
6	S70 K80 259	REACTOR		3	3	3	3	3	3		ACL1,2,3
7	S70 E11 208H	HIGH PRESSURE SENSOR		1	1	1	1	1	1		63HS
8	S70 E02 413	CHARGE PLUG		1	1	1	1	1	1		
9	S70 E62 202	THERMISTOR (DISCHARGE)	D8	1	1	1	1	1	1		TH4
10	S70 600 418	STOP VALVE (LIQUID)	3/8"	1	1	1	1	1	1		
11	S70 E02 004	RUBBER MOUNT		4	4	4	4	4	4		
12	S70 E60 400	COMPRESSOR	ANB33FJQMT	1	1	1	1	1	1		MC
13	S70 E06 411	BALL VALVE (GAS)	5/8"	1	1	1	1	1	1		
14	S70 E75 440H	POWER RECEIVER (ACCUMULATOR)		1	1	1	1	1	1		
15	S70 36L 450	STRAINER	#50	1	1	1	1	1	1		
16	S70 E54 202	THERMISTOR (COMP.SURFACE)		1	1	1	1	1	1		TH34
17	S70 E37 202	THERMISTOR-H (LIQUID)	1150 XA	1	1	1	1	1	1		TH3
18	S70 E66 202	THERMISTOR (SUCTION)	2/G950XA	1	1	1	1	1	1		TH32
19	S70 H20 209	LOW PRESSURE SWITCH		1	1	1	1	1	1		63L
20	S70 E87 402	LINEAR EXPANSION VALVE COIL	UKV-A211	1	1	1	1	1	1	Connector: Red	LEV-B
21	S70 E92 401	LINEAR EXPANSION VALVE	UKV-32D135	2	2	2	2	2	2	FOR LEV-A,B/A,C	
22	S70 42H 467	MUFFLER		1	1	1	1	1	1		
23	S70 E05 403	REVERSING VALVE (4-WAY VALVE)		1	1	1	1	1	1		
24	S70 E63 202	THERMISTOR	1000-3P	1	1	1	1	1	1		TH33
25	S70 E88 402	LINEAR EXPANSION VALVE COIL	UKV-A212	1	1	1	1	1	1	Connector: White	LEV-A
26	S70 E99 402	LINEAR EXPANSION VALVE COIL	UKV	1	1	1	1	1	1	Connector: Blue	LEV-C
27	S70 E80 401	EXPANSION VALVE	UKV-18D35	1	1	1	1	1	1	FOR LEV-C	
28	S70 E60 202	THERMISTOR-W (OUTDOOR,2-PHASE PIPE, AMBIENT)		1	1	1	1	1	1		TH6,7
29	S70 E08 242	SOLENOID COIL <4WAY COIL>		1	1	1	1	1	1		21S4
30	S70 E10 208H	HIGH PRESSURE SWITCH	OFF 4.14MPa	1	1	1	1	1	1		63H
31	S70 E03 413	CHARGE PLUG		1	1	1	1	1	1		
32	S70 E77 313	POWER BOARD		1	1	1	1	1	1		P.B
33	S70 E75 313	CONVERTOR BOARD		1	1	1	1	1	1		CONV.B
34	S70 E75 346	NOISE FILTER BOARD		1	1	1	1	1	1		N.F
35	S70 E56 315H	CONTROLLER BOARD		1	1	1	1	1	1		C.B
36	S70 E09 716	TERMINAL BED	5P(L1, L2, L3,N, E)	1	1	1	1	1	1		TB1
37	S70 E08 716	TERMINAL BED	3P(S1, S2, S3)	1	1	1	1	1	1		TB2
38	S70 K90 259	REACTOR		1	1	1	1	1	1		ACL4
39	S70 E71 255	CAPACITOR		1	1	1	1	1	1		CK
40	S70 E20 234	RESISTOR		1	1	1	1	1	1		RS
④1	S70 E55 202	THERMISTOR (HEAT SINK)		1	1	1	1	1	1		TH8

**STRUCTURAL PARTS**  
**PUHZ-SHW80VHA**  
**PUHZ-SHW112VHA**  
**PUHZ-SHW112YHA**  
**PUHZ-SHW140YHA**

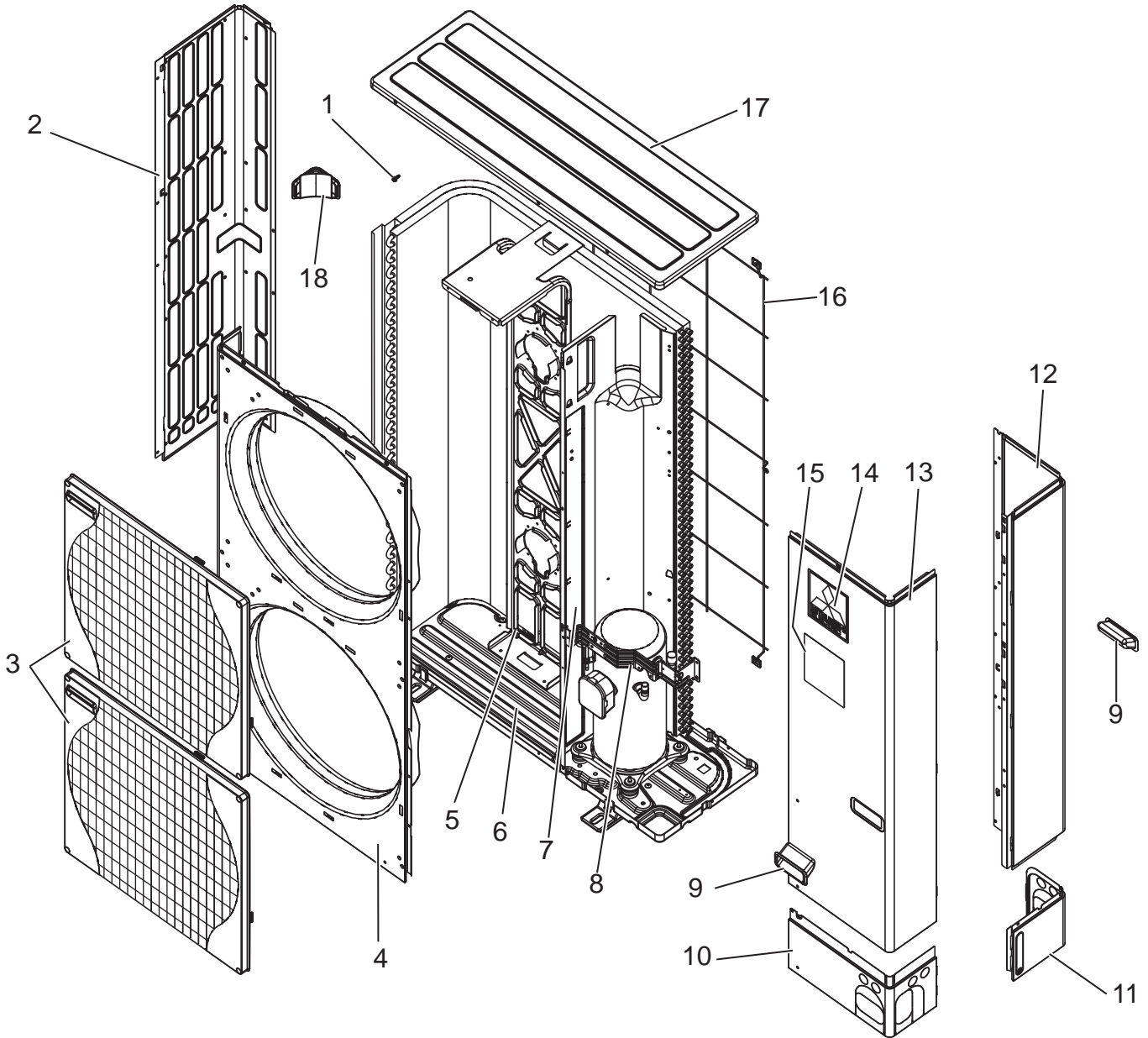



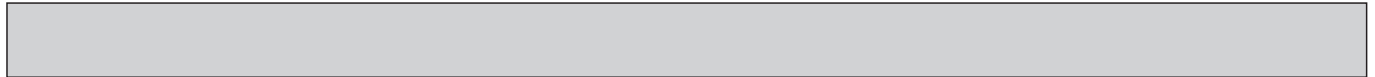

No.	Part No.	Part Name	Specifi- cation	Q'ty/unit				Remarks (Drawing No.)	Wiring Diagram Symbol
				PUHZ-SHW					
				80VHA	112VHA	112YHA	140YHA		
1	—	F.ST SCREW	(5×12)	38	38	38	38	(DG12F536H12)	
2	R01 E33 662	SIDE PANEL (L)		1	1	1	1		
3	R01 E33 691	FAN GRILLE		2	2	2	2		
4	R01 E16 668	FRONT PANEL		1	1	1	1		
5	R01 E19 130	MOTOR SUPPORT		1	1	1	1		
6	R01 E26 686	BASE ASSY		1	1	1	1		
7	—	SEPARATOR ASSY		1	1			(BK00C143GK6)	
	—	SEPARATOR ASSY				1	1	(BK00C409G49)	
8	—	VALVE BED ASSY		1	1	1	1	(BK00C142G28)	
9	R01 E01 655	HANDLE		2	2	2	2		
10	R01 E26 658	COVER PANEL (FRONT)		1	1	1	1		
11	R01 E25 658	COVER PANEL (REAR)		1	1	1	1		
12	R01 E44 661	SIDE PANEL (R)		1	1	1	1		
13	T7W E08 667	SERVICE PANEL		1	1	1	1		
14	—	LABEL (MITSUBISHI)		1	1	1	1	(DG79R130H03)	
15	—	BRAND LABEL		1	1	1	1	(BH79L116H03)	
16	R01 E07 698	REAR GUARD		1	1	1	1		
17	R01 E29 641	TOP PANEL		1	1				
	R01 E27 641	TOP PANEL				1	1		
18	R01 E02 655	HANDLE		1	1	1	1		

**STRUCTURAL PARTS**  
**PUHZ-SHW112YHAR1**  
**PUHZ-SHW140YHAR1**

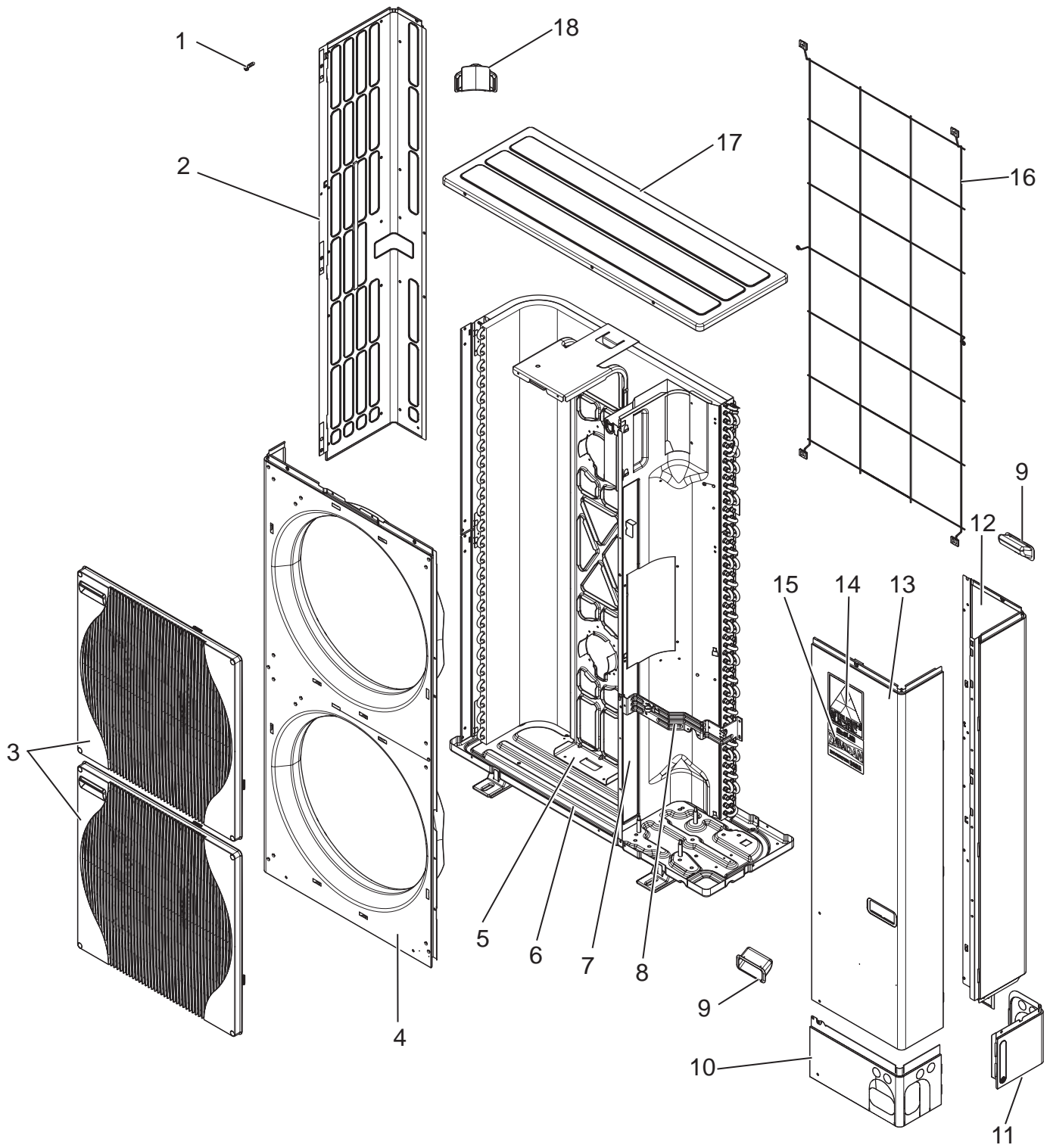

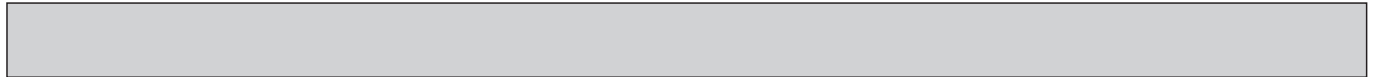

No.	Part No.	Part Name	Specifi- cation	Q'ty/unit		Remarks (Drawing No.)	Wiring Diagram Symbol
				PUHZ-SHW-YHAR1			
				112	140		
1	—	F.ST SCREW	(5×12)	38	38	(DG12F536H12)	
2	R01 E33 662	SIDE PANEL (L)		1	1		
3	R01 E33 691	FAN GRILLE		2	2		
4	R01 E16 668	FRONT PANEL		1	1		
5	R01 E19 130	MOTOR SUPPORT		1	1		
6	R01 E26 686	BASE ASSY		1	1		
7	—	SEPARATOR ASSY		1	1	(BK00C409G49)	
8	—	VALVE BED ASSY		1	1	(BK00C142G28)	
9	R01 E01 655	HANDLE		2	2		
10	R01 E26 658	COVER PANEL (FRONT)		1	1		
11	R01 E25 658	COVER PANEL (REAR)		1	1		
12	R01 E44 661	SIDE PANEL (R)		1	1		
13	T7W E08 667	SERVICE PANEL		1	1		
14	—	LABEL (MITSUBISHI)		1	1	(DG79R130H03)	
15	—	BRAND LABEL		1	1	(BH79L116H03)	
16	R01 E07 698	REAR GUARD		1	1		
17	R01 E27 641	TOP PANEL		1	1		
18	R01 E02 655	HANDLE		1	1		

**STRUCTURAL PARTS**

PUHZ-SHW80VHAR2.UK

PUHZ-SHW80VHAR2-BS.UK

PUHZ-SHW112VHAR2.UK

PUHZ-SHW112VHAR2-BS.UK

PUHZ-SHW112YHAR2.UK

PUHZ-SHW112YHAR2-BS.UK

PUHZ-SHW140YHAR2.UK

PUHZ-SHW140YHAR2-BS.UK

PUHZ-SHW80VHAR3.UK

PUHZ-SHW80VHAR3-BS.UK

PUHZ-SHW112VHAR3.UK

PUHZ-SHW112VHAR3-BS.UK

PUHZ-SHW112YHAR3.UK

PUHZ-SHW112YHAR3-BS.UK

PUHZ-SHW140YHAR3.UK

PUHZ-SHW140YHAR3-BS.UK

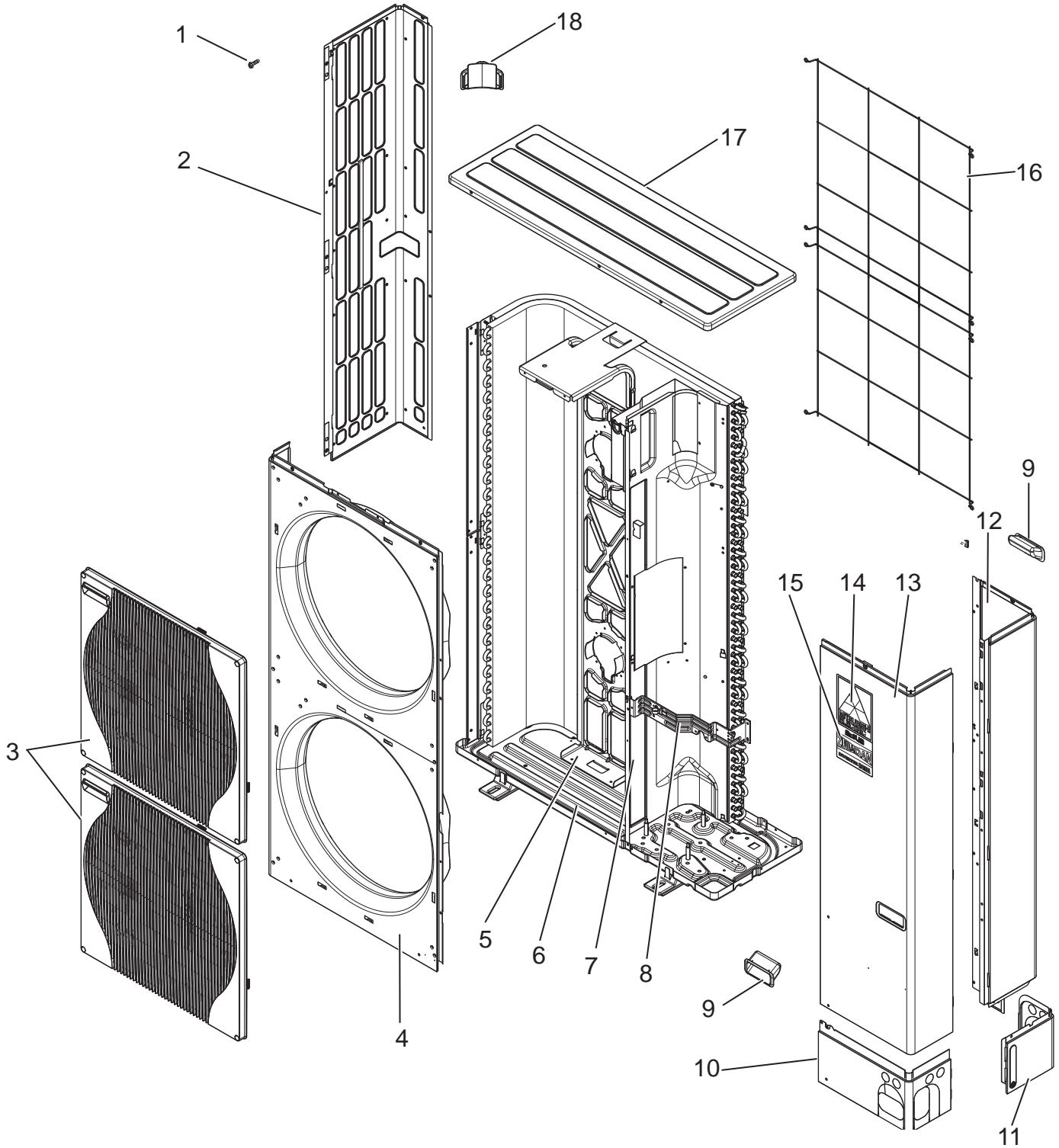

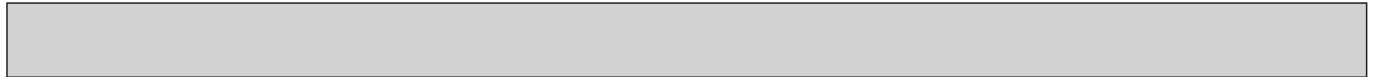

No.	Part No.	Part Name	Specifi- cation	Q'ty/unit																Remarks (Drawing No.)
				PUHZ-SHW80VHAR2.UK	PUHZ-SHW80VHAR2-BS.UK	PUHZ-SHW112VHAR2.UK	PUHZ-SHW112VHAR2-BS.UK	PUHZ-SHW112VHAR2.UK	PUHZ-SHW112VHAR2-BS.UK	PUHZ-SHW140YHAR2.UK	PUHZ-SHW140YHAR2-BS.UK	PUHZ-SHW80VHAR3.UK	PUHZ-SHW80VHAR3-BS.UK	PUHZ-SHW112VHAR3.UK	PUHZ-SHW112VHAR3-BS.UK	PUHZ-SHW112VHAR3.UK	PUHZ-SHW112VHAR3-BS.UK	PUHZ-SHW140YHAR3.UK	PUHZ-SHW140YHAR3-BS.UK	
1	—	F.ST SCREW	(5x12)	50	50	50	50	50	50	50	50	50	50	50	50	50	50	50	DG12F536H12-JP	
2	S 70 E 15 6 6 2	SIDE PANEL (L)		1		1		1		1		1		1		1				
	S 70 E 16 6 6 2	SIDE PANEL (L)			1		1		1		1		1		1		1			
3	S 70 E 30 6 7 5	FAN GRILLE		2	2	2	2	2	2	2	2	2	2	2	2	2	2	2		
4	S 70 E 40 6 6 8	FRONT PANEL		1		1		1		1		1		1		1				
	S 70 E 51 6 6 8	FRONT PANEL			1		1		1		1		1		1		1			
5	S 70 E 20 1 3 0	MOTOR SUPPORT		1		1		1		1		1		1		1				
	S 70 E 80 1 3 0	MOTOR SUPPORT			1		1		1		1		1		1		1			
6	S 70 E 71 6 8 6	BASE ASSY		1		1		1		1		1		1		1				
	S 70 E 81 6 8 6	BASE ASSY			1		1		1		1		1		1		1			
7	—	SEPARATOR		1		1						1		1				BK00C456G76		
	—	SEPARATOR						1		1					1		1	BK00C456G77		
	—	SEPARATOR			1		1					1		1				BK00C456G78		
	—	SEPARATOR							1		1					1		1	BK00C456G79	
8	S 71 0 V B 0 0 1	VALVE BED ASSY		1	1	1	1	1	1	1	1	1	1	1	1	1	1	1		
9	S 70 3 0 L 6 5 5	HANDLE		2	2	2	2	2	2	2	2	2	2	2	2	2	2	2		
10	S 70 E 30 6 5 8	COVER PANEL (FRONT)		1		1		1		1		1		1		1				
	S 70 E 31 6 5 8	COVER PANEL (FRONT)			1		1		1		1		1		1		1			
11	S 70 E 40 6 5 8	COVER PANEL (REAR)		1		1		1		1		1		1		1				
	S 70 E 41 6 5 8	COVER PANEL (REAR)			1		1		1		1		1		1		1			
12	S 70 E 80 6 6 2	SIDE PANEL(R)		1		1		1		1		1		1		1				
	S 70 E 90 6 6 2	SIDE PANEL(R)			1		1		1		1		1		1		1			
13	S 70 E 31 6 6 1	SERVICE PANEL		1		1		1		1		1		1		1				
	S 70 E 41 6 6 1	SERVICE PANEL			1		1		1		1		1		1		1			
14	S 70 E 20 6 9 9	LABEL (MITSUBISHI)		1	1	1	1	1	1	1	1	1	1	1	1	1	1	1		
15	S 70 E 30 6 9 9	LABEL (BRAND)		1	1	1	1	1	1	1	1	1	1	1	1	1	1	1		
16	S 70 E 20 6 9 8	REAR GUARD		2	2	2	2	2	2	2	2	2	2	2	2	2	2	2		
17	S 70 E 20 6 4 1	TOP PANEL		1		1		1		1		1		1		1				
	S 70 E 30 6 4 1	TOP PANEL			1		1		1		1		1		1		1			
18	S 70 E 10 6 5 5	HANDLE		1	1	1	1	1	1	1	1	1	1	1	1	1	1	1		

## STRUCTURAL PARTS

PUHZ-SHW80VHAR4.UK

PUHZ-SHW80VHAR4-BS.UK

PUHZ-SHW112YHAR4.UK

PUHZ-SHW112YHAR4-BS.UK

PUHZ-SHW112VHAR4.UK

PUHZ-SHW112VHAR4-BS.UK

PUHZ-SHW140YHAR4.UK

PUHZ-SHW140YHAR4-BS.UK

PUHZ-SHW140YHAR5.UK

PUHZ-SHW140YHAR5-BS.UK

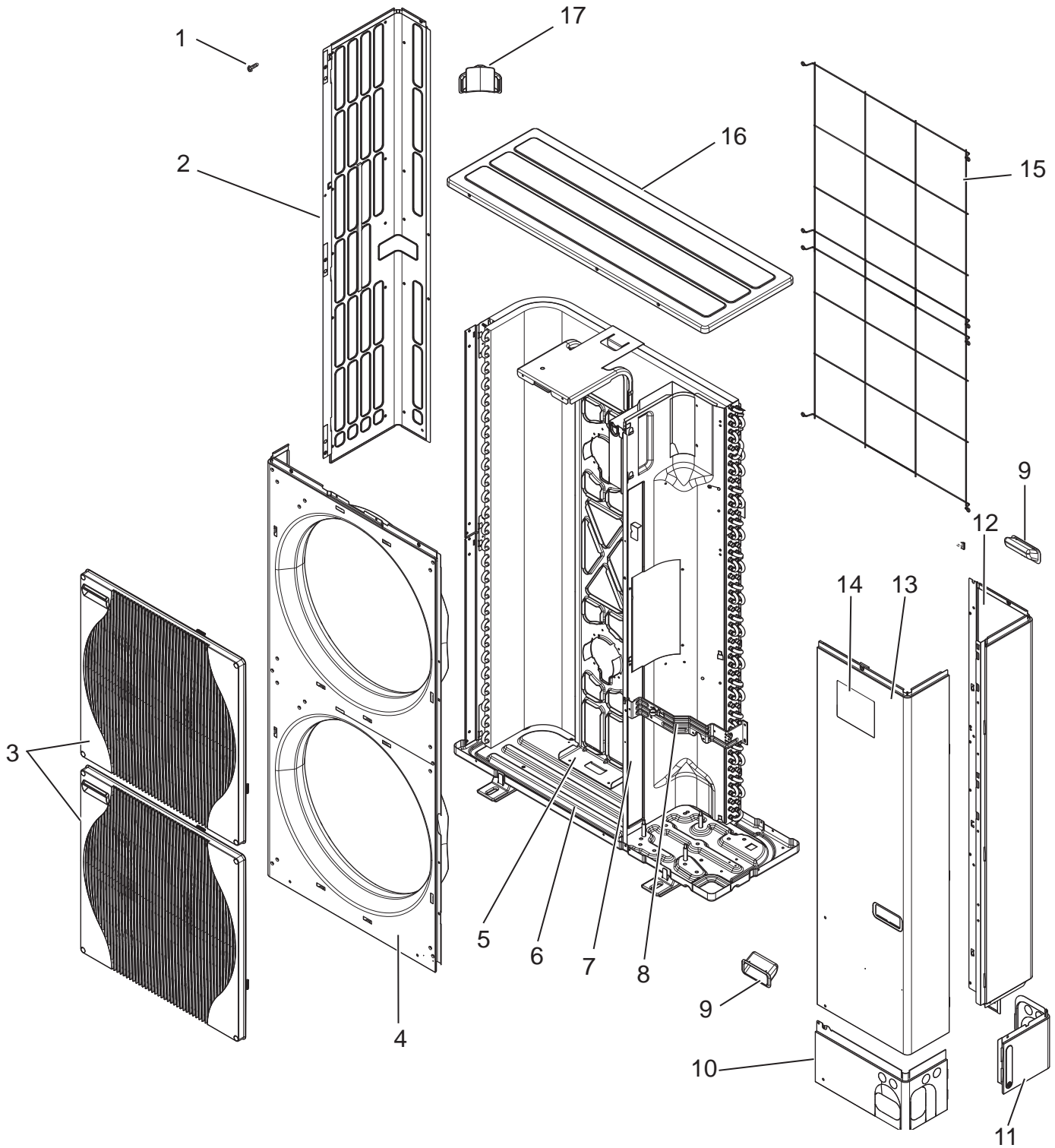

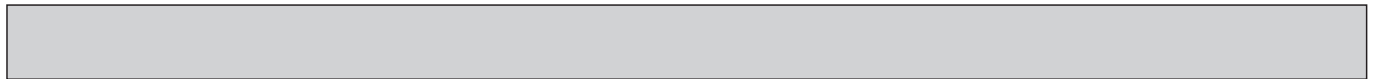



No.	Part No.	Part Name	Specifi- cation	Q'ty/unit										Remarks (Drawing No.)	
				PUHZ-SHW80VHAR4.UK	PUHZ-SHW80VHAR4-BS.UK	PUHZ-SHW112VHAR4.UK	PUHZ-SHW112VHAR4-BS.UK	PUHZ-SHW112YHAR4.UK	PUHZ-SHW112YHAR4-BS.UK	PUHZ-SHW140YHAR4.UK	PUHZ-SHW140YHAR4-BS.UK	PUHZ-SHW140YHAR5.UK	PUHZ-SHW140YHAR5-BS.UK		
1	—	F.ST SCREW	(5x12)	50	50	50	50	50	50	50	50	50	50	50	DG12F536H12-JP
2	S 70 E 15 6 6 2	SIDE PANEL (L)		1		1		1		1		1			
	S 70 E 16 6 6 2	SIDE PANEL (L)			1		1		1		1		1		
3	S 70 E 30 6 7 5	FAN GRILLE		2	2	2	2	2	2	2	2	2	2	2	
4	S 70 E 40 6 6 8	FRONT PANEL		1		1		1		1		1			
	S 70 E 51 6 6 8	FRONT PANEL			1		1		1		1		1		
5	S 70 E 25 1 3 0	MOTOR SUPPORT		1		1		1		1		1			
	S 70 E 85 1 3 0	MOTOR SUPPORT			1		1		1		1		1		
6	S 70 E 72 6 8 6	BASE ASSY		1		1		1		1		1			
	S 70 E 82 6 8 6	BASE ASSY			1		1		1		1		1		
7	—	SEPARATOR		1		1									BK00C456G76
	—	SEPARATOR						1		1		1			BK00C456G77
	—	SEPARATOR			1		1								BK00C456G78
	—	SEPARATOR							1		1		1		BK00C456G79
8	S 71 0 V B 0 0 1	VALVE BED ASSY		1	1	1	1	1	1	1	1	1	1	1	
9	S 70 3 0 L 6 5 5	HANDLE		2	2	2	2	2	2	2	2	2	2	2	
10	S 70 E 30 6 5 8	COVER PANEL (FRONT)		1		1		1		1		1			
	S 70 E 31 6 5 8	COVER PANEL (FRONT)			1		1		1		1		1		
11	S 70 E 40 6 5 8	COVER PANEL (REAR)		1		1		1		1		1			
	S 70 E 41 6 5 8	COVER PANEL (REAR)			1		1		1		1		1		
12	S 70 E 80 6 6 2	SIDE PANEL(R)		1		1		1		1		1			
	S 70 E 90 6 6 2	SIDE PANEL(R)			1		1		1		1		1		
13	S 70 E 31 6 6 1	SERVICE PANEL		1		1		1		1		1			
	S 70 E 41 6 6 1	SERVICE PANEL			1		1		1		1		1		
14	S 70 E 35 6 9 9	LABEL (MITSUBISHI)		1	1	1	1	1	1	1	1	1	1	1	
15	S 70 E 20 6 9 8	REAR GUARD		2	2	2	2	2	2	2	2	2	2	2	
16	S 70 E 20 6 4 1	TOP PANEL		1		1		1		1		1			
	S 70 E 30 6 4 1	TOP PANEL			1		1		1		1		1		
17	S 70 E 10 6 5 5	HANDLE		1	1	1	1	1	1	1	1	1	1	1	

## CONNECTOR FOR DRAIN HOSE HEATER

Parts No.

PAC-SE60RA-E

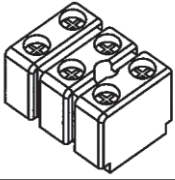
## Contents

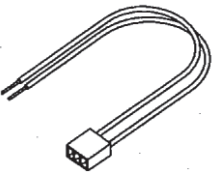
① Terminal block	×1
	
② Screw	×1
	
③ Lead wire with connector	×1
	

## Installation

## ● PUAZ-SHW80/112VHA

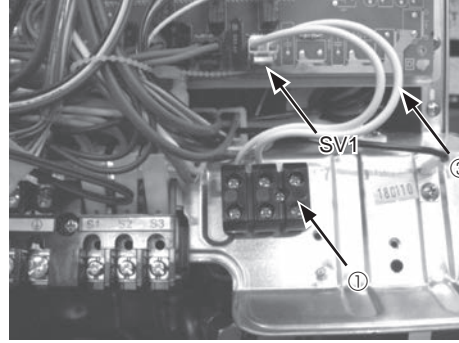

## ● PUAZ-SHW112/140YHA

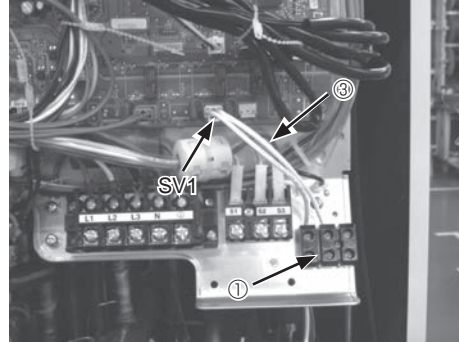

1. Attach the terminal block ①, with the screw ②.
2. Connect the lead wire ③ connector side to SV1 port on the outdoor controller board.
3. Connect the lead wire ③ to the terminal block ①.
4. Wire local cables for a drain hose heater RELAY to the terminal block ①.

- Drain hose heater RELAY connection only
- MAX current 1A

## Circuit diagram example

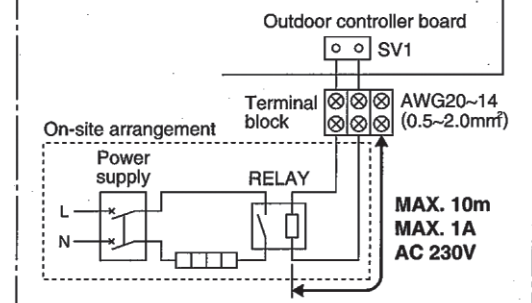

SV1 on the controller board  
→ Drain hose heater signal output  
With PAC-SE60RA-E

From defrost start  
For 15 min. ON signal provided

## MITSUBISHI ELECTRIC CORPORATION

HEAD OFFICE: TOKYO BUILDING, 2-7-3, MARUNOUCHI, CHIYODA-KU, TOKYO 100-8310, JAPAN