

PARTS CATALOG

R410A

[Model Name]

[Service Ref.]

PUHZ-SHW230YKA2

PUHZ-SHW230YKA2
PUHZ-SHW230YKA2R1
PUHZ-SHW230YKA2R2

Revisions:

- Some descriptions have been modified in REVISED EDITION-D.

OCB594 REVISED EDITION-C is void.

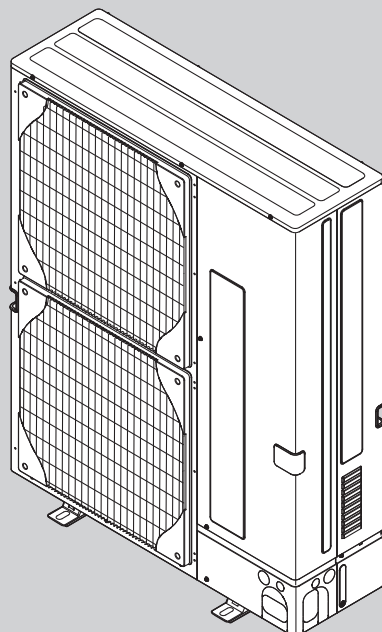

CONTENTS

1. SERVICE PARTS LIST 2
2. OPTIONAL PARTS 8

SERVICE MANUAL (OCH594)

1

SERVICE PARTS LIST

FUNCTIONAL AND ELECTRICAL PARTS
PUHZ-SHW230YKA2
PUHZ-SHW230YKA2R1

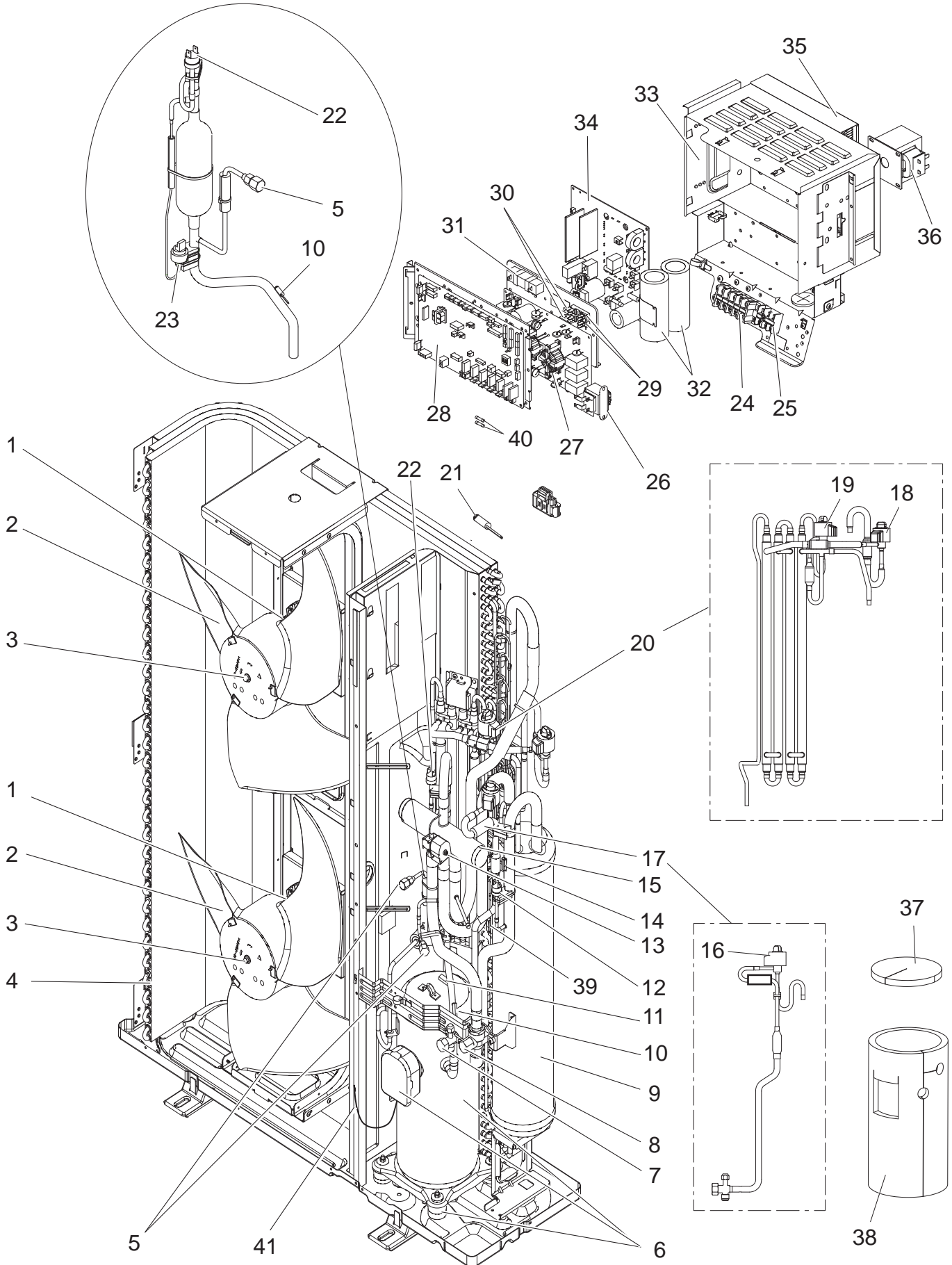



No.	Parts No.	Parts Name	Specification	Q'ty/unit		Remarks (Drawing No.)	Wiring Diagram Symbol
				PUHZ-SHW230YKA2	PUHZ-SHW230YKA2R1		
1	R01 E75 221	FAN MOTOR		2			MF1, 2
	R01 E95 221	FAN MOTOR			2		MF1, 2
2	R01 E10 115	PROPELLER FAN/D550		2	2		
3	R01 E09 097	NUT M6	M6	2			
	R01 E16 097	CAP NUT (MEC) M6	M6		2		
4	T7W E81 408	HEAT EXCHANGER		1	1		
5	R01 E24 413	CHARGE PLUG/LB90		2	2		
6	T97 423 077	COMPRESSOR	ANB66FJNMT	1	1	Includes RUBBER MOUNTS & TERMINAL COVER	MC
7	R01 E23 410	STOP VALVE 1/2F	1/2F	1	1		
8	R01 E13 411	BALL VALVE & STRAINER	3/4F	1	1		
9	T7W E21 440	POWER RECEIVER		1	1		
10	T7W E17 201	THERMISTOR	Discharge	1	1		TH4
11	R01 H90 202	THERMISTOR	Comp.Surface	1	1		TH34
12	R01 E00 209	LOW PRESSURE SWITCH		1	1		63L
13	T7W E41 242	SOLENOID COIL(21S4)		1	1		21S4
14	R01 H17 202	THERMISTOR	Suction	1	1		TH32
15	R01 E12 403	4WAY VALVE		1	1		21S4
16	R01 H13 242	COIL (LEV)/XAP - 5P RED		1	1		LEV-B
17	T7W E74 401	LEV ASSY-B/REC-V		1	1	Includes LEV-B Coil & STOP VALVE	
18	R01 H09 242	COIL (LEV)/XAP - 5P WH		1	1		LEV-A
19	R01 H14 242	COIL (LEV)/XAP - 5P BLU		1	1		LEV-C
20	T7W E65 401	LEV ASSY HIC		1	1	Includes LEV-A, C coil	
21	R01 N00 202	THERMISTOR W	2-Phase Pipe, Ambient	1	1		TH6, 7
22	R01 E06 208	HIGH PRESSURE SWITCH	OFF 4.14MPa	1	1		63H
23	R01 E07 208	HIGH PRESSURE SENSOR		1	1		63HS
24	T7W E30 716	T.B./L1.L2.L3.N.E	5P (L1,L2,L3,N,⊕)	1	1		TB1
25	R01 E19 246	T.B./S1.S2.S3	3P (S1,S2,S3)	1	1		TB2
26	T7W E16 259	REACTOR		1	1		ACL4
27	T7W E32 346	NOISE FILTER		1	1		N.F.
28	T7W GX1 315	CONTROLLER BOARD		1	1		C.B.
29	R01 30L 241	FUSE HOLDER		2	2		
30	R01 E07 239	FUSE 15 A 250 V	15 A, 250 V	2	2		FUSE1, 2
31	R01 E10 233	RESISTOR		1	1		RS
32	R01 E02 254	CAPACITOR		2	2		CB1,2
33	—	ELECTRICAL PARTS BOX		1	1	(BK00B702G64)	
34	T7W E59 313	POWER BOARD		1	1		P.B.
35	T7W A01 371	HEAT SINK		1	1	Includes SCREWS	
36	T7W E13 259	REACTOR		1	1		DCL
37	R01 A57 602	COMP FELT(TOP)		1	1		
38	R01 A70 602	COMP FELT(BODY)		1			
	T7W A13 602	COMP FELT(BODY)			1		
39	R01 E96 202	THERMISTOR	Liquid	1	1		TH3
40	R01 E14 239	FUSE 6.3 A 250 V	6.3 A, 250 V	2	2		F3, 4
41	R01 E29 510	LEAD ASSY COMP		1	1		

FUNCTIONAL AND ELECTRICAL PARTS
PUHZ-SHW230YKA2R2

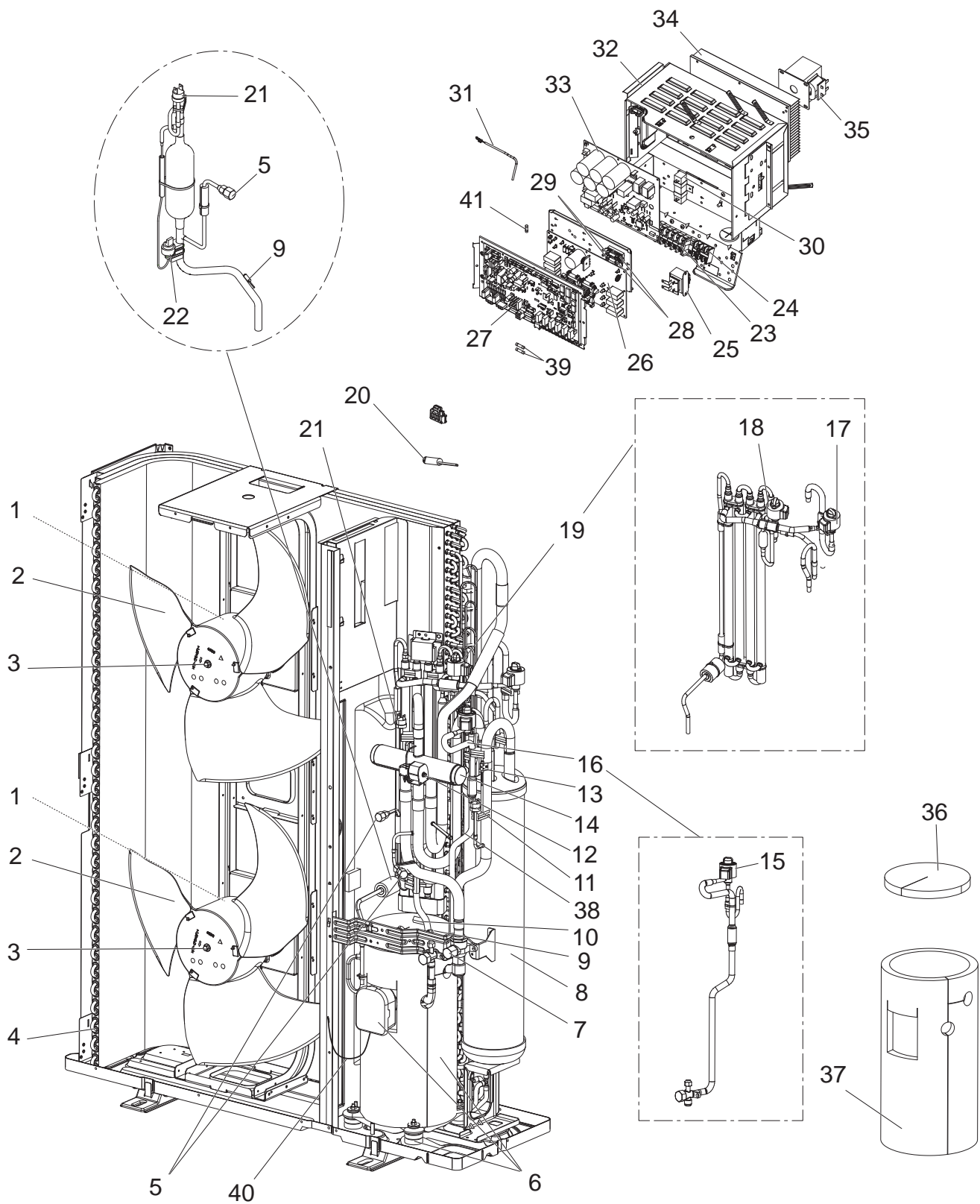



No.	Parts No.	Parts Name	Specification	Q'ty/ unit	Remarks (Drawing No.)	Wiring Diagram Symbol
				PUHZ-SHW230YKA2R2		
1	R01 E95 221	FAN MOTOR		2		MF1, 2
2	R01 E10 115	PROPELLER FAN/D550		2		
3	R01 E16 097	CAP NUT (MEC) M6	M6	2		
4	T7W H81 408	HEAT EXCHANGER		1		
5	R01 E24 413	CHARGE PLUG/LB90		2		
6	T97 423 077	COMPRESSOR	ANB66FJNMT	1	Includes RUBBER MOUNTS & TERMINAL COVER	MC
7	R01 E13 411	BALL VALVE & STRAINER	3/4F	1		
8	T7W H21 440	POWER RECEIVER		1		
9	T7W E17 201	THERMISTOR	Discharge	1		TH4
10	R01 H90 202	THERMISTOR	Comp.Surface	1		TH34
11	R01 H00 209	LOW PRESSURE SWITCH		1		63L
12	T7W E57 242	SOLENOID COIL(21S4)		1		21S4
13	R01 H17 202	THERMISTOR	Suction	1		TH32
14	R01 E12 403	4WAY VALVE		1		21S4
15	R01 H47 242	COIL (LEV)/XAP - 5P RED		1		LEV-B
16	T7W B04 401	LEV ASSY - B/REC - V		1	Includes LEV-B Coil & STOP VALVE	
17	R01 HR7 242	COIL (LEV)/XAP - 5P WH		1		LEV-A
18	R01 H41 242	COIL (LEV)/XAP - 5P BLU		1		LEV-C
19	T7W A04 401	HIC & LEV - A ASSY		1	Includes LEV-A, C coil	
20	R01 N00 202	THERMISTOR W	2-Phase Pipe, Ambient	1		TH6, 7
21	R01 H06 208	HIGH PRESSURE SWITCH	OFF 4.14MPa	1		63H
22	R01 H07 208	HIGH PRESSURE SENSOR		1		63HS
23	T7W E30 716	T.B./L1.L2.L3.N.E	5P (L1,L2,L3,N,⊕)	1		TB1
24	R01 E19 246	T.B./S1.S2.S3	3P (S1,S2,S3)	1		TB2
25	T7W E16 259	REACTOR		1		ACL4
26	T7W E38 346	NOISE FILTER		1		N.F.
27	T7W S05 315	CONTROLLER BOARD		1		C.B.
28	R01 30L 241	FUSE HOLDER		2		
29	R01 E07 239	FUSE 15 A 250 V	15 A, 250 V	2		FUSE1, 2
30	R01 E10 233	RESISTOR		1		RS
31	R01 M16 202	THERMISTOR (HS)		1		TH8
32	—	ELECTRICAL PARTS BOX		1	(BK00B702G66)	
33	T7W S03 323	POWER BOARD		1		P.B.
34	R01 A11 371	HEAT SINK		1	Includes SCREWS	
35	T7W E13 259	REACTOR		1		DCL
36	R01 A57 602	COMP FELT(TOP)		1		
37	T7W A13 602	COMP FELT(BODY)		1		
38	R01 E96 202	THERMISTOR	Liquid	1		TH3
39	R01 E14 239	FUSE 6.3 A 250 V	6.3 A, 250 V	2		F3, 4
40	T7W C00 510	LEAD ASSY COMP		1		
41	R01 E06 239	FUSE 6.3A 250V		1		FUSE

STRUCTURAL PARTS
PUHZ-SHW230YKA2
PUHZ-SHW230YKA2R1
PUHZ-SHW230YKA2R2

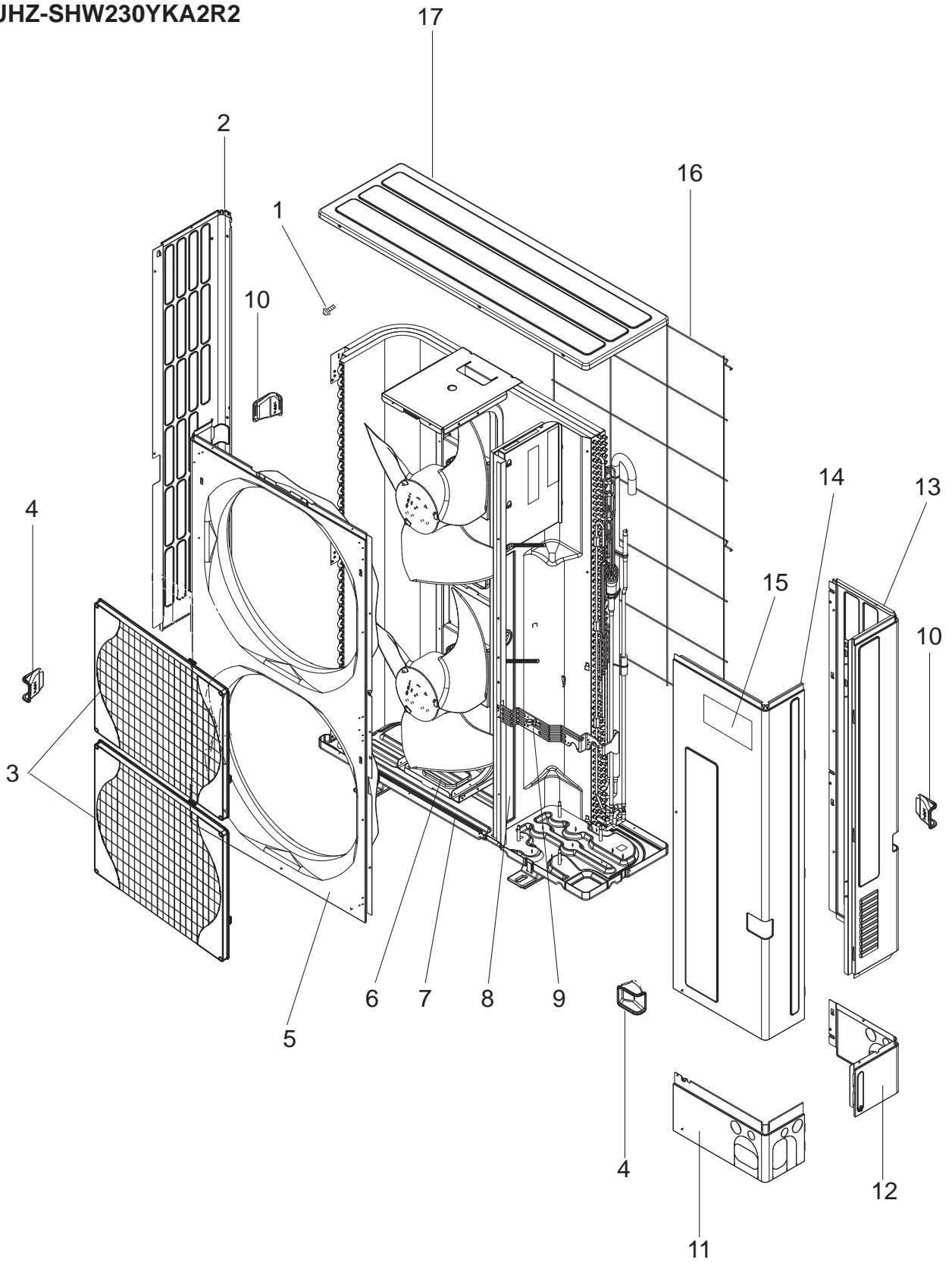



No.	Parts No.	Parts Name	Specification	Q'ty/unit			Remarks (Drawing No.)	Wiring Diagram Symbol	Recom- mended Q'ty
				PUHZ-SHW230YKA2	PUHZ-SHW230YKA2R1	PUHZ-SHW230YKA2R2			
1	—	F.ST SCREW	(5x12)	38	38	38	(BT12L041H12)		
2	R01 E30 662	SIDE PANEL (L)		1	1	1			
3	T7W E08 691	FAN GRILLE		2	2	2			
4	R01 E04 655	HANDLE		2	2	2			
5	T7W E13 667	FRONT PANEL		1	1	1			
6	T7W E19 130	MOTOR SUPPORT		1	1	1			
7	R01 E53 686	BASE ASSY		1	1	1			
8	—	SEPARATOR		1	1	1	(BK00B817GQ7)		
9	—	VALVE BED ASSY		1	1	1	(BK00C375G49)		
10	R01 E03 655	HANDLE		2	2	2			
11	R01 E41 658	COVER PANEL (FRONT)		1	1	1			
12	R01 E42 658	COVER PANEL (REAR)		1	1	1			
13	T7W E30 661	SIDE PANEL (R)		1	1	1			
14	T7W E19 668	SERVICE PANEL		1	1	1			
15	T7W A04 005	BRAND LABEL (ZUBADAN)		1	1	1			
16	R01 E10 698	REAR GUARD		1	1	1			
17	R01 E36 641	TOP PANEL		1	1	1			

Parts name	Parts No.
AIR OUTLET GUIDE*	PAC-SH96SG-E
AIR GUIDE*	PAC-SH95AG-E
DRAIN SOCKET	PAC-SG61DS-E
DRAIN PAN	PAC-SH97DP-E
DISTRIBUTION PIPE (Twin)	MSDD-50WR-E
DISTRIBUTION PIPE (Triple)	MSDT-111R-E
DISTRIBUTION PIPE (Quadruple)	MSDF-1111R-E
A-CONTROL SERVICE TOOL	PAC-SK52ST
FILTER DRYER FOR LIQUID PIPE (ø9.52)	PAC-SG82DR-E
FILTER DRYER FOR LIQUID PIPE (ø12.7)	PAC-SG85DR-E
M-NET ADAPTER	PAC-S9 5MA-E
A INTERFACE	PAC-SK82SI-E
∅ INT PIPE Connected pipes diameter (ø9.52 → ø12.7)	PAC-SG73RJ E
∅ INT PIPE Connected pipes diameter (ø12.7 → ø15.88)	PAC-SG74RJ E
∅ INT PIPE Connected pipes diameter (ø15.88 → ø19.05)	PAC-SG75RJ E
CONNECTOR FOR DRAIN HOSE HEATER	PAC-SE60RA-E
CAPACITY STEP CONTROL INTERFACE	PAC-IF011B-E
AHU STEP INTERFACE	PAC-IF013B-E

*Need 2 pieces

MITSUBISHI ELECTRIC CORPORATION

HEAD OFFICE : TOKYO BUILDING, 2-7-3, MARUNOUCHI, CHIYODA-KU, TOKYO 100-8310, JAPAN