

# PARTS CATALOG R32

**<Outdoor unit>**
**[Model Name]**

PUZ-WM50VHA

PUZ-WM60VAA

PUZ-WM85VAA

PUZ-WM85YAA

PUZ-WM112VAA

PUZ-WM112YAA

**[Service Ref.]**
**PUZ-WM50VHA.UK**
**PUZ-WM60VAA.UK**
**PUZ-WM85VAA.UK**
**PUZ-WM85YAA.UK**
**PUZ-WM112VAA.UK**
**PUZ-WM112YAA.UK**
**Salt proof model**

PUZ-WM50VHA-BS

PUZ-WM60VAA-BS

PUZ-WM85VAA-BS

PUZ-WM85YAA-BS

PUZ-WM112VAA-BS

PUZ-WM112YAA-BS

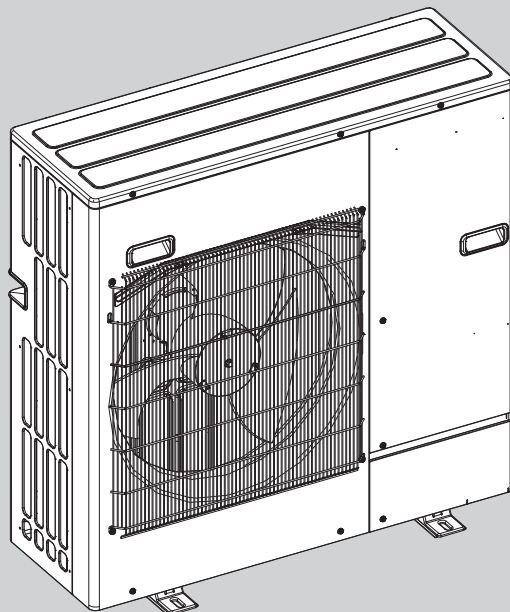
**PUZ-WM50VHA-BS.UK**
**PUZ-WM60VAA-BS.UK**
**PUZ-WM85VAA-BS.UK**
**PUZ-WM85YAA-BS.UK**
**PUZ-WM112VAA-BS.UK**
**PUZ-WM112YAA-BS.UK**

**PUZ-WM50VHA.UK**
**CONTENTS**

- |                            |    |
|----------------------------|----|
| 1. SERVICE PARTS LIST..... | 2  |
| 2. OPTIONAL PARTS.....     | 18 |

**SERVICE MANUAL (OCH727)**

**FUNCTIONAL AND ELECTRICAL PARTS**

**PUZ-WM50VHA.UK**

**PUZ-WM50VHA-BS.UK**

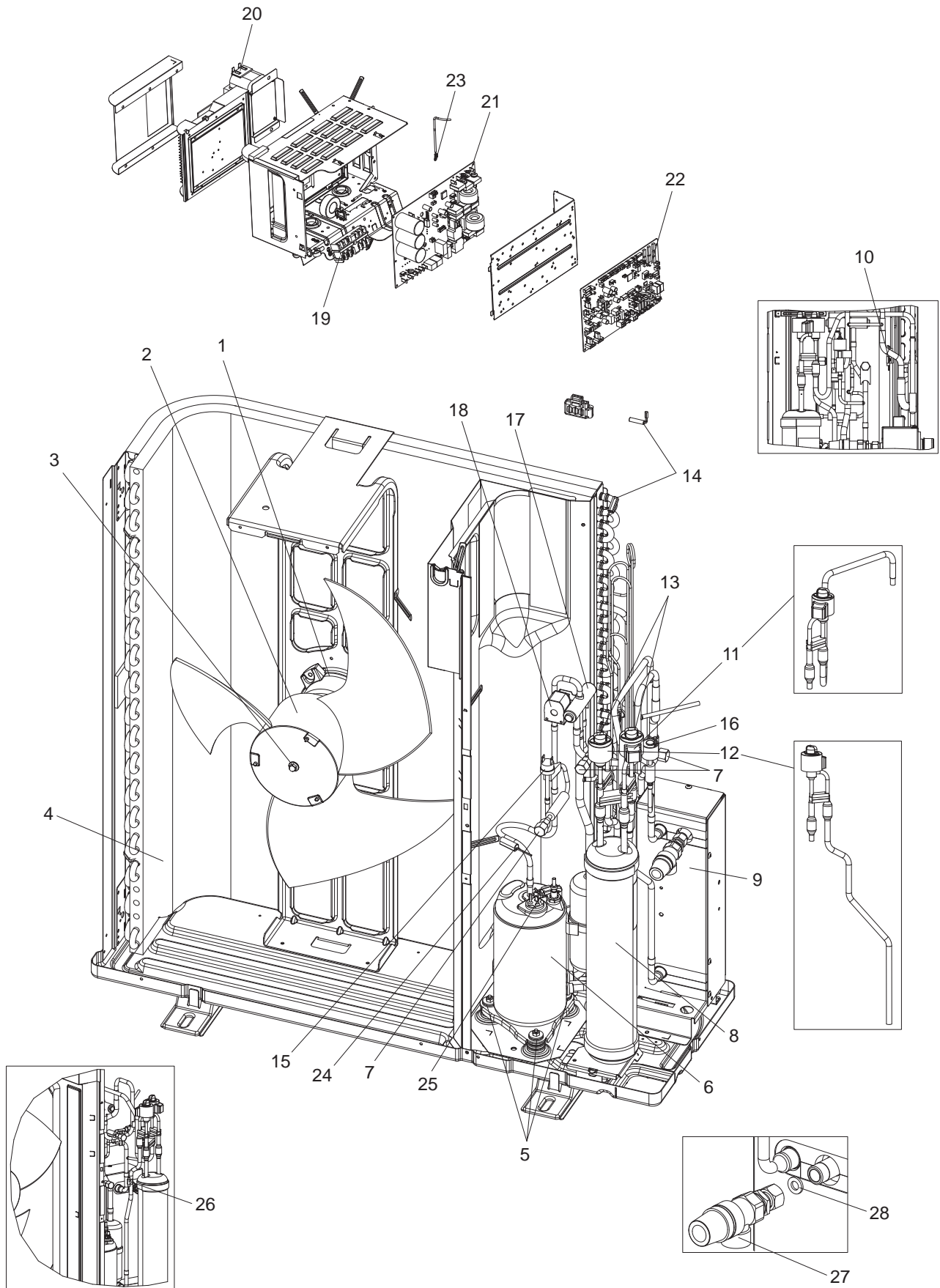

1. The part quantity below indicates the required number of pieces per unit.
2. The circled No. indicates that the part is not shown in the figure.

No.	Parts No.	Parts Name	PUZ-WM50VHA.UK	PUZ-WM50VHA-BS.UK	Wiring Diagram Symbol	Remarks [Drawing No.]
1	S70 E91 763	FAN MOTOR	1	1	MF1	
2	S70 K04 115	PROPELLER FAN	1	1		
3	S70 K01 097	NUT	1	1		
4	S70 E46 408	HEAT EXCHANGER	1	1		
5	S70 E03 004	RUBBER MOUNT	3	3		
6	S70 E31 400	COMPRESSOR	1	1	MC	SVB130FBBMC-L3
7	S70 E03 413	CHARGE PLUG	1	1		
7	S70 E02 413	CHARGE PLUG	2	2		
8	S70 E45 440	RECEIVER (ACCUMULATOR)	1	1		
9	S70 W95 408	PLATE HEAT EXCHANGER	1	1		ACH30-50
10	S70 E52 202	THERMISTOR-H (LIQUID)	1	1	TH3	850XAP
11	S70 E88 402	LINEAR EXPANSION VALVE COIL	1	1	LEV(A)	UKV-A212 CONNECTOR WHITE
12	S70 E87 402	LINEAR EXPANSION VALVE COIL	1	1	LEV(B)	UKV-A211 CONNECTOR RED
13	S70 E95 401	LINEAR EXPANSION VALVE	2	2		(UKV-18D124)
14	S70 E31 202	THERMISTOR-W (2-PHASE PIPE, AMBIENT)	1	1	TH6/TH7	850/1050
15	S70 E14 208	HIGH PRESSURE SWITCH	1	1	63H	OFF 4.14MPA
16	S70 E13 208	HIGH PRESSURE SENSOR	1	1	63HS	L=1160
17	S70 E13 403	REVERSING VALVE	1	1		
18	S70 E25 242	SOLENOID COIL <4WAY COIL>	1	1	21S4	
19	S70 E11 716	TERMINAL BLOCK	1	1	TB1	6P (L, N, E + S1, S2, S3)
20	S70 K45 259	REACTOR	1	1	DCL	
21	S70 E67 313	POWER CIRCUIT BOARD	1	1	P.B	
22	S70 E59 315	CONTROLLER CIRCUIT BOARD	1	1	C.B	
23	S70 E70 202	THERMISTOR (HEAT SINK SENSOR)	1	1	TH8	
24	S70 E59 202	THERMISTOR (DISCHARGE)	1	1	TH4	
25	S70 E84 202	THERMISTOR (COMP. SURFACE)	1	1	TH33	
26	S70 E83 202	THERMISTOR (PLATE HEX LIQUID)	1	1	TH34	1150/ 2P
27	S70 C50 404	PRESSURE RELIEF VALVE ASSY	1	1		
28	S70 C99 460	GASKET 9.52	1	1		G3/8"

Do not reuse the gaskets (No.28) that were once removed, but be sure to replace with a new one.

**FUNCTIONAL AND ELECTRICAL PARTS**  
**PUZ-WM60VAA.UK**  
**PUZ-WM60VAA-BS.UK**  
**PUZ-WM85VAA.UK**  
**PUZ-WM85VAA-BS.UK**

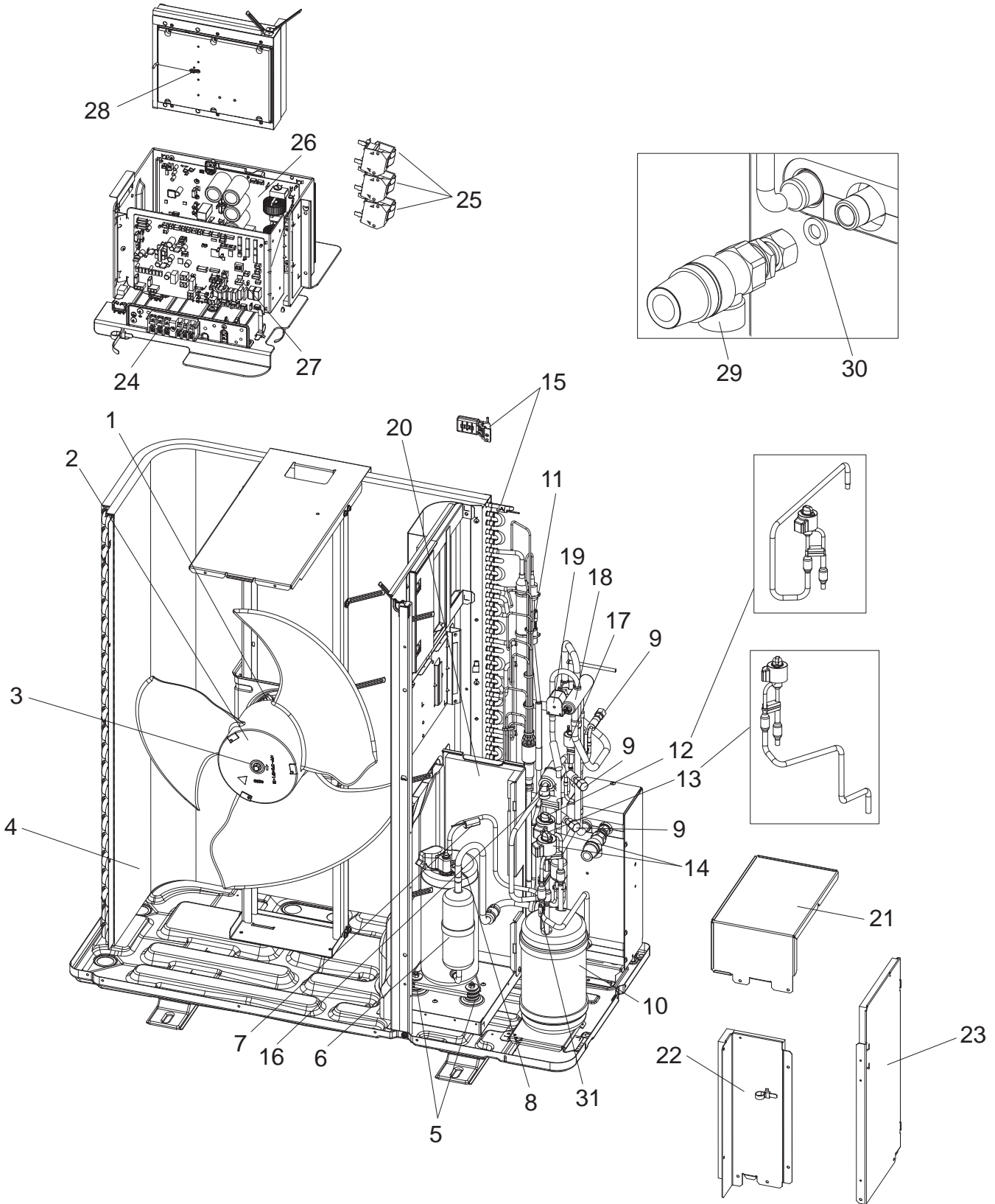

1. The part quantity below indicates the required number of pieces per unit.
2. The circled No. indicates that the part is not shown in the figure.

No.	Parts No.	Parts Name	PUZ-WM60VAA.UK	PUZ-WM60VAA-BS.UK	PUZ-WM85VAA.UK	PUZ-WM85VAA-BS.UK	Wiring Diagram Symbol	Remarks [Drawing No.]
1	S70 E95 763	FAN MOTOR	1	1	1	1	MF1	
2	S70 E50 115	PROPELLER FAN	1	1	1	1		
3	S70 K01 097	NUT	1	1	1	1		
4	S70 E43 408H	HEAT EXCHANGER	1	1	1	1		
5	S70 E03 004	RUBBER MOUNT	3	3	3	3		
6	S70 E26 400	COMPRESSOR	1	1	1	1	MC	SVB220FEGMC
7	S70 E77 202	THERMISTOR (DISCHARGE)	1	1	1	1	TH4	
8	S70 E73 202	THERMISTOR (COMP. SURFACE)	1	1	1	1	TH33	
9	S70 E04 413	CHARGE PLUG	3	3	3	3		
10	S70 E55 440	RECEIVER	1	1	1	1		
11	S70 E47 202	THERMISTOR-H (LIQUID)	1	1	1	1	TH3	1050 XAP
12	S70 E88 402	LINEAR EXPANSION VALVE COIL	1	1	1	1	LEV-A	UKV-A212
13	S70 E87 402	LINEAR EXPANSION VALVE COIL	1	1	1	1	LEV-B	UKV-A211
14	S70 E80 401	LINEAR EXPANSION VALVE	2	2	2	2		UKV-18D35
15	S70 E75 202	THERMISTOR-W (2-PHASE PIPE, AMBIENT)	1	1	1	1	TH6/7	950/1150
16	S70 E14 208	HIGH PRESSURE SWITCH	1	1	1	1	63H	OFF 4.14MPA
17	S70 E13 208	HIGH PRESSURE SENSOR	1	1	1	1		L=1160
18	S70 E11 403	REVERSING VALVE	1	1	1	1		
19	S70 E20 242	SOLENOID COIL <4WAY COIL>	1	1	1	1	21S4	
20	S70 E06 005	COMP CASE BACK	1	1	1	1		
21	S70 E06 008	COMP CASE TOP	1	1	1	1		
22	S70 E06 006H	COMP CASE FRONT	1	1	1	1		
23	S70 E06 007	COMP CASE SIDE	1	1	1	1		
24	S70 E11 716	TERMINAL BLOCK	1	1	1	1	TB1	6P(L,N,E + S1,S2,S3)
25	S70 K95 259	REACTOR	3	3	3	3	DCL1,2,3	
26	S70 E63 313	POWER CIRCUIT BOARD	1	1	1	1	P.B.	
27	S70 E58 315	CONTROLLER CIRCUIT BOARD	1	1	1	1	C.B.	
28	S70 E76 202	THERMISTOR (HEAT SINK)	1	1	1	1	TH8	
29	S70 C50 404	PRESSURE RELIEF VALVE ASSY	1	1	1	1		
30	S70 C99 460	GASKET 9.52	1	1	1	1		G3/8"
31	S70 E82 202	THERMISTOR (PLATE HEX LIQUID)	1	1	1	1	TH34	1150/2P

Do not reuse the gaskets (No.30) that were once removed, but be sure to replace with a new one.

**FUNCTIONAL AND ELECTRICAL PARTS**  
**PUZ-WM112VAA.UK**  
**PUZ-WM112VAA-BS.UK**

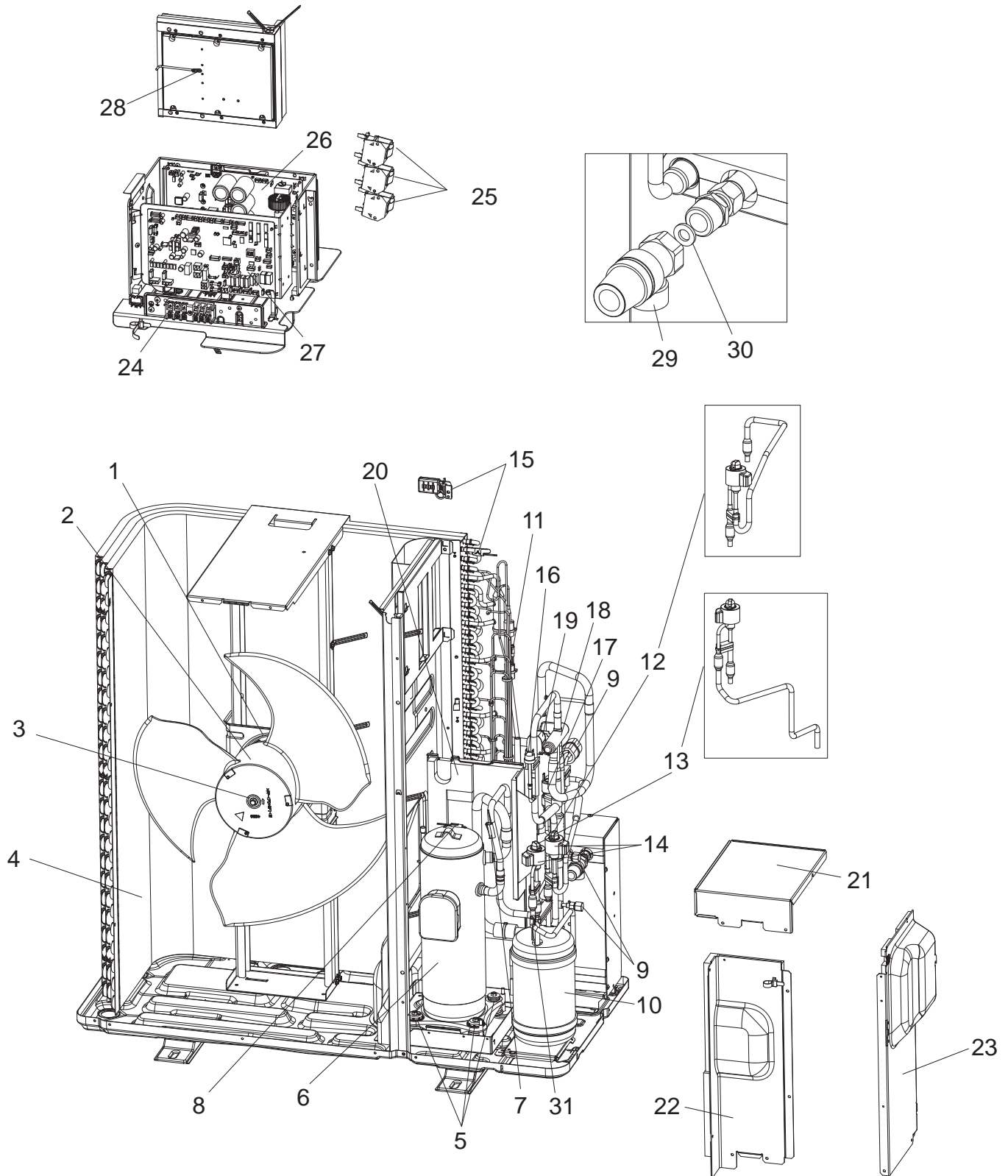

1. The part quantity below indicates the required number of pieces per unit.
2. The circled No. indicates that the part is not shown in the figure.

No.	Parts No.	Parts Name	PUZ-WM112VAA.UK	PUZ-WM112VAA-BS.UK	Wiring Diagram Symbol	Remarks [Drawing No.]
1	S70 E96 763	FAN MOTOR	1	1	MF1	
2	S70 E50 115	PROPELLER FAN	1	1		
3	S70 K01 097	NUT	1	1		
4	S70 E42 408H	HEAT EXCHANGER	1	1		
5	S70 E04 004	RUBBER MOUNT	4	4		
6	S70 E28 400	COMPRESSOR	1	1	MC	DVB28FBAMT
7	S70 E78 202	THERMISTOR (DISCHARGE)	1	1	TH4	
8	S70 E74 202	THERMISTOR (COMP. SURFACE)	1	1	TH33	
9	S70 E04 413	CHARGE PLUG	3	3		
10	S70 E55 440	RECEIVER	1	1		
11	S70 E47 202	THERMISTOR-H (LIQUID)	1	1	TH3	1050 XAP
12	S70 E88 402	LINEAR EXPANSION VALVE COIL	1	1	LEV-A	UKV-A212
13	S70 E87 402	LINEAR EXPANSION VALVE COIL	1	1	LEV-B	UKV-A211
14	S70 E80 401	LINEAR EXPANSION VALVE	2	2		UKV-18D35
15	S70 E75 202	THERMISTOR-W (2-PHASE PIPE, AMBIENT)	1	1	TH6/7	950/1150
16	S70 E14 208	HIGH PRESSURE SWITCH	1	1	63H	OFF 4.14MPA
17	S70 E13 208	HIGH PRESSURE SENSOR	1	1		L=1160
18	S70 E12 403	REVERSING VALVE	1	1		
19	S70 E20 242	SOLENOID COIL <4WAY COIL>	1	1	21S4	
20	S70 E07 005	COMP CASE BACK	1	1		
21	S70 E07 008	COMP CASE TOP	1	1		
22	S70 E07 006H	COMP CASE FRONT	1	1		
23	S70 E05 007	COMP CASE SIDE	1	1		
24	S70 E11 716	TERMINAL BLOCK	1	1	TB1	6P(L,N,E + S1,S2,S3)
25	S70 K95 259	REACTOR	3	3	DCL1,2,3	
26	S70 E59 313	POWER CIRCUIT BOARD	1	1	P.B.	
27	S70 E58 315	CONTROLLER CIRCUIT BOARD	1	1	C.B.	
28	S70 E76 202	THERMISTOR (HEAT SINK)	1	1	TH8	
29	S70 C50 404	PRESSURE RELIEF VALVE ASSY	1	1		
30	S70 C99 460	GASKET 9.52	1	1		G3/8"
31	S70 E82 202	THERMISTOR (PLATE HEX LIQUID)	1	1	TH34	1150/2P

Do not reuse the gaskets (No.30) that were once removed, but be sure to replace with a new one.

**FUNCTIONAL AND ELECTRICAL PARTS**  
**PUZ-WM85YAA.UK**  
**PUZ-WM85YAA-BS.UK**

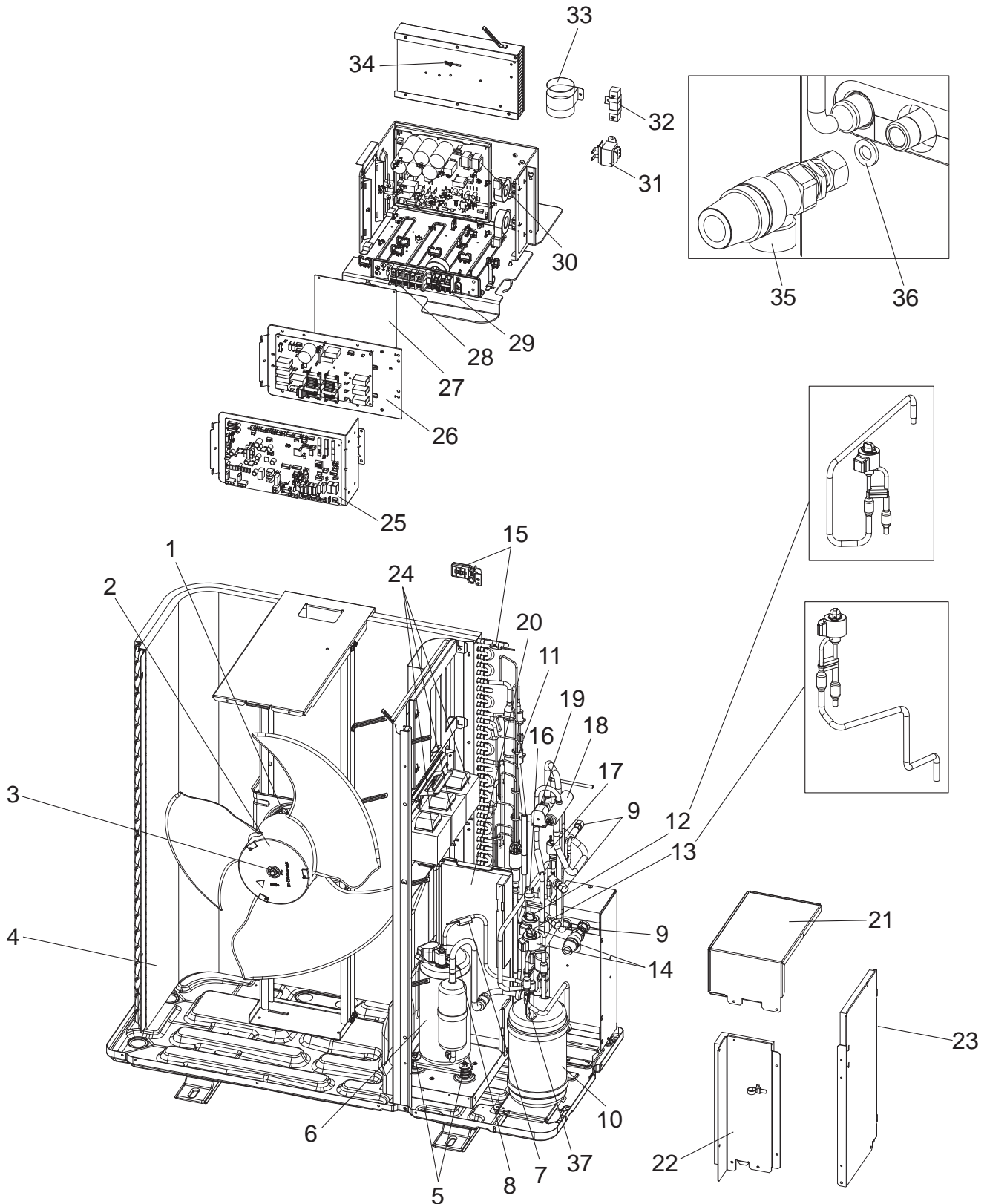



1. The part quantity below indicates the required number of pieces per unit.
2. The circled No. indicates that the part is not shown in the figure.

No.	Parts No.	Parts Name	PUZ-WM85YAA.UK	PUZ-WM85YAA-BS.UK	Wiring Diagram Symbol	Remarks [Drawing No.]
1	S70 E95 763	FAN MOTOR	1	1	MF1	
2	S70 E50 115	PROPELLER FAN	1	1		
3	S70 K01 097	NUT	1	1		
4	S70 E43 408H	HEAT EXCHANGER	1	1		
5	S70 E03 004	RUBBER MOUNT	3	3		
6	S70 E27 400	COMPRESSOR	1	1	MC	SVB220FEAMC
7	S70 E77 202	THERMISTOR (DISCHARGE)	1	1	TH4	
8	S70 E73 202	THERMISTOR (COMP. SURFACE)	1	1	TH33	
9	S70 E04 413	CHARGE PLUG	3	3		
10	S70 E55 440	RECEIVER	1	1		
11	S70 E47 202	THERMISTOR-H (LIQUID)	1	1	TH3	1050 XAP
12	S70 E88 402	LINEAR EXPANSION VALVE COIL	1	1	LEV-A	UKV-A212
13	S70 E87 402	LINEAR EXPANSION VALVE COIL	1	1	LEV-B	UKV-A211
14	S70 E80 401	LINEAR EXPANSION VALVE	2	2		UKV-18D35
15	S70 E75 202	THERMISTOR-W (2-PHASE PIPE, AMBIENT)	1	1	TH6/7	950/1150
16	S70 E14 208	HIGH PRESSURE SWITCH	1	1	63H	OFF 4.14MPA
17	S70 E13 208	HIGH PRESSURE SENSOR	1	1		L=1160
18	S70 E11 403	REVERSING VALVE	1	1		
19	S70 E20 242	SOLENOID COIL <4WAY COIL>	1	1	21S4	
20	S70 E06 005	COMP CASE BACK	1	1		
21	S70 E06 008	COMP CASE TOP	1	1		
22	S70 E06 006H	COMP CASE FRONT	1	1		
23	S70 E06 007	COMP CASE SIDE	1	1		
24	S70 K80 259	REACTOR	3	3	ACL	
25	S70 E58 315	CONTROLLER CIRCUIT BOARD	1	1	C.B.	
26	S70 E25 346	NOISE FILTER ASSY	1	1	N.F.	
27	S70 E66 313	CONVERTOR CIRCUIT BOARD	1	1	CONV.B.	
28	S70 E09 716	TERMINAL BLOCK	1	1	TB1	5P(L1,L2,L3,N,E)
29	S70 E08 716	TERMINAL BLOCK	1	1	TB2	3P(S1/S2/S3)
30	S70 E64 313	POWER CIRCUIT BOARD	1	1	P.B.	
31	S70 K90 259	REACTOR	1	1	ACL4	
32	S70 E20 234	RESISTOR	1	1	RS	
33	S70 E81 255	CAPACITOR	1	1	CK	30uF
34	S70 E55 202	THERMISTOR (HEAT SINK)	1	1	TH8	
35	S70 C50 404	PRESSURE RELIEF VALVE ASSY	1	1		
36	S70 C99 460	GASKET 9.52	1	1		G3/8"
37	S70 E82 202	THERMISTOR (PLATE HEX LIQUID)	1	1	TH34	1150/2P

Do not reuse the gaskets (No.36) that were once removed, but be sure to replace with a new one.

**FUNCTIONAL AND ELECTRICAL PARTS**  
**PUZ-WM112YAA.UK**  
**PUZ-WM112YAA-BS.UK**

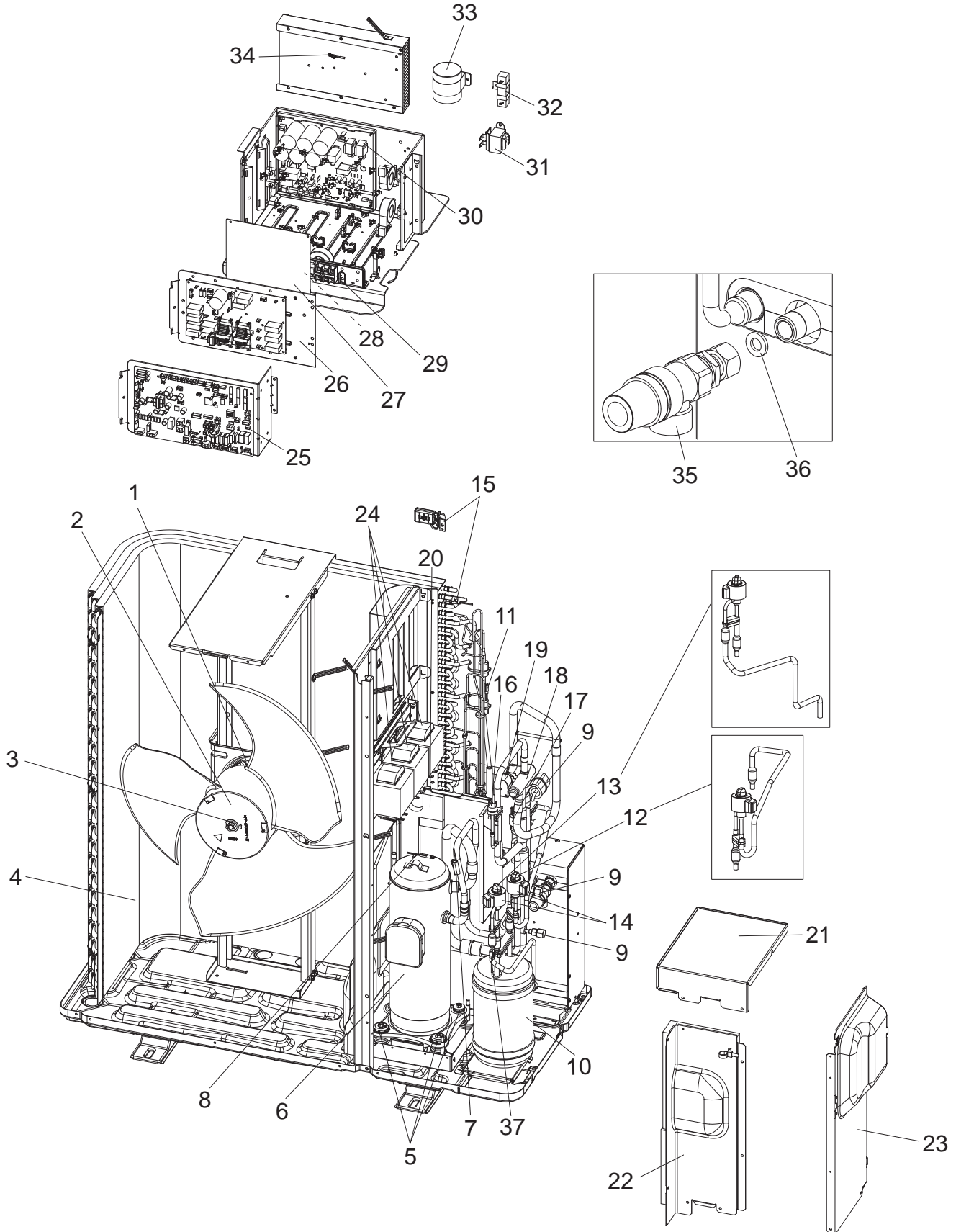

1. The part quantity below indicates the required number of pieces per unit.
2. The circled No. indicates that the part is not shown in the figure.

No.	Parts No.	Parts Name	PUZ-WM112YAA.UK	PUZ-WM112YAA-BS.UK	Wiring Diagram Symbol	Remarks [Drawing No.]
1	S70 E96 763	FAN MOTOR	1	1	MF1	
2	S70 E50 115	PROPELLER FAN	1	1		
3	S70 K01 097	NUT	1	1		
4	S70 E42 408H	HEAT EXCHANGER	1	1		
5	S70 E04 004	RUBBER MOUNT	4	4		
6	S70 E29 400	COMPRESSOR	1	1	MC	DVB28FBBMT
7	S70 E78 202	THERMISTOR (DISCHARGE)	1	1	TH4	
8	S70 E74 202	THERMISTOR (COMP. SURFACE)	1	1	TH33	
9	S70 E04 413	CHARGE PLUG	3	3		
10	S70 E55 440	RECEIVER	1	1		
11	S70 E47 202	THERMISTOR-H (LIQUID)	1	1	TH3	1050 XAP
12	S70 E88 402	LINEAR EXPANSION VALVE COIL	1	1	LEV-A	UKV-A212
13	S70 E87 402	LINEAR EXPANSION VALVE COIL	1	1	LEV-B	UKV-A211
14	S70 E80 401	LINEAR EXPANSION VALVE	2	2		UKV-18D35
15	S70 E75 202	THERMISTOR-W (2-PHASE PIPE, AMBIENT)	1	1	TH6/7	950/1150
16	S70 E14 208	HIGH PRESSURE SWITCH	1	1	63H	OFF 4.14MPA
17	S70 E13 208	HIGH PRESSURE SENSOR	1	1		L=1160
18	S70 E12 403	REVERSING VALVE	1	1		
19	S70 E20 242	SOLENOID COIL <4WAY COIL>	1	1	21S4	
20	S70 E07 005	COMP CASE BACK	1	1		
21	S70 E07 008	COMP CASE TOP	1	1		
22	S70 E07 006H	COMP CASE FRONT	1	1		
23	S70 E05 007	COMP CASE SIDE	1	1		
24	S70 K80 259	REACTOR	3	3	ACL	
25	S70 E58 315	CONTROLLER CIRCUIT BOARD	1	1	C.B.	
26	S70 E25 346	NOISE FILTER ASSY	1	1	N.F.	
27	S70 E66 313	CONVERTER CIRCUIT BOARD	1	1	CONV.B.	
28	S70 E09 716	TERMINAL BLOCK	1	1	TB1	5P(L1,L2,L3,N,E)
29	S70 E08 716	TERMINAL BLOCK	1	1	TB2	3P(S1/S2/S3)
30	S70 E61 313	POWER CIRCUIT BOARD	1	1	P.B.	
31	S70 K90 259	REACTOR	1	1	ACL4	
32	S70 E20 234	RESISTOR	1	1	RS	
33	S70 E81 255	CAPACITOR	1	1	CK	30uF
34	S70 E55 202	THERMISTOR (HEAT SINK)	1	1	TH8	
35	S70 C50 404	PRESSURE RELIEF VALVE ASSY	1	1		
36	S70 C99 460	GASKET 9.52	1	1		G3/8"
37	S70 E82 202	THERMISTOR (PLATE HEX LIQUID)	1	1	TH34	1150/2P

Do not reuse the gaskets (No.36) that were once removed, but be sure to replace with a new one.

**STRUCTURAL PARTS**  
**PUZ-WM50VHA.UK**  
**PUZ-WM50VHA-BS.UK**

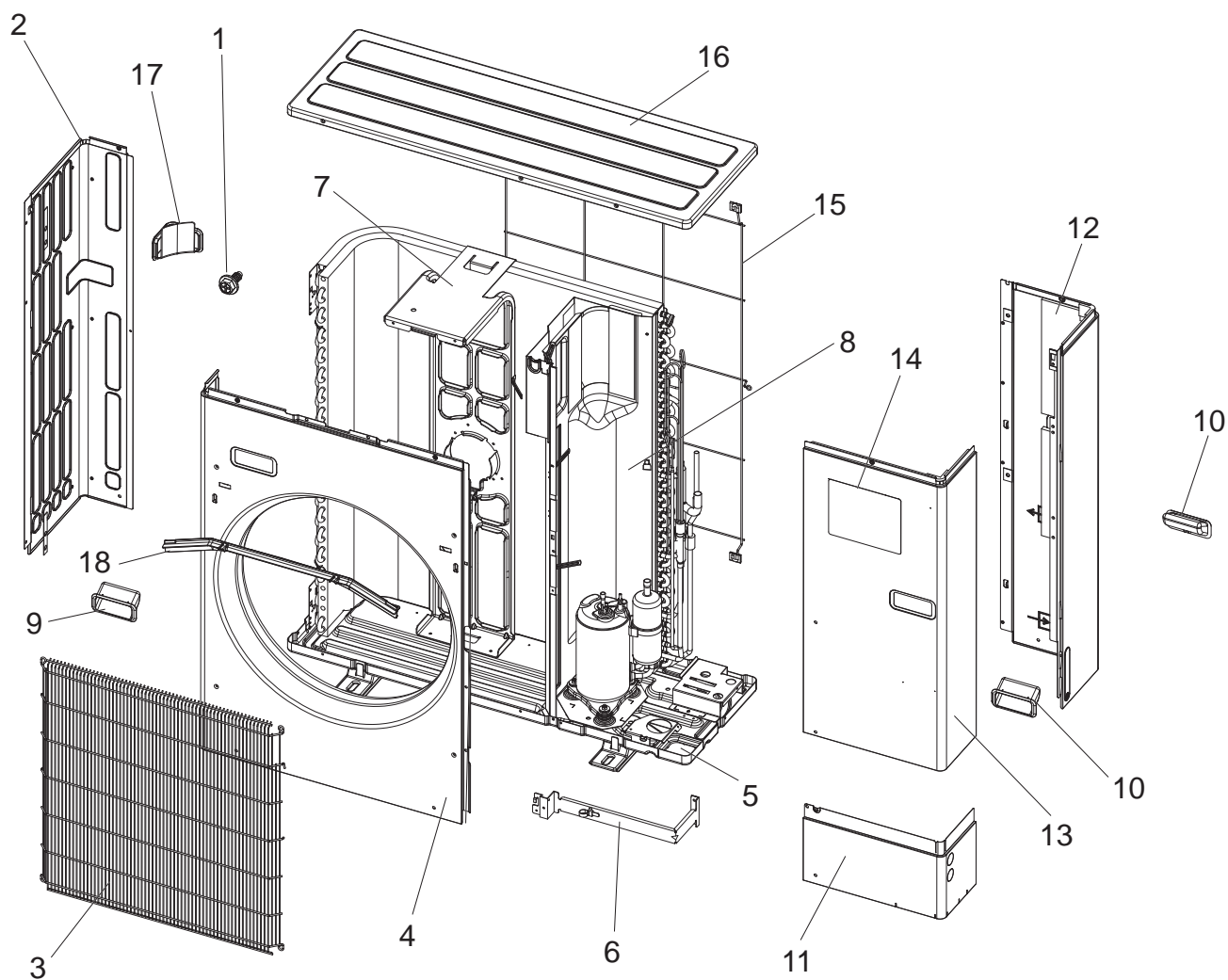

1. The part quantity below indicates the required number of pieces per unit.
2. The circled No. indicates that the part is not shown in the figure.

No.	Parts No.	Parts Name	PUZ-WM50VHA.UK	PUZ-WM50VHA-BS.UK	Remarks [Drawing No.]
1	—	F.ST SCREW	31	31	(5x12) [DG12F536H12-JP]
2	S70 E24 662	SIDE PANEL (L)	1		
2	S70 E25 662	SIDE PANEL (L)		1	
3	S70 E05 675	WIRE GRILLE	1	1	
4	S70 E31 668	FRONT PANEL	1		
4	S70 E41 668	FRONT PANEL		1	
5	S70 E32 686	BASE ASSY	1		
5	S70 E43 686	BASE ASSY		1	
6	S71 VBA 850	VALVE BED ASSY (STAY)	1	1	
7	S70 E15 130	MOTOR SUPPORT	1		
7	S70 E45 130	MOTOR SUPPORT		1	
8	—	SEPARATOR	1		[BK00C456G44]
8	—	SEPARATOR		1	[BK00C456G39]
9	S70 E60 655	HANDLE	1	1	BLACK
10	S70 E70 655	HANDLE	2	2	WHITE
11	S70 E77 658	COVER PANEL (FRONT)	1		
11	S70 E78 658	COVER PANEL (FRONT)		1	
12	S70 E32 662	SIDE PANEL(R)/COVER PANEL(R)	1		
12	S70 E42 662	SIDE PANEL(R)/COVER PANEL(R)		1	
13	S70 E75 661	SERVICE PANEL	1		
13	S70 E76 661	SERVICE PANEL		1	
14	S70 E55 699	BRAND LABEL (ECODAN)	1	1	
15	S70 E10 698	REAR GUARD	1	1	
16	S70 E90 641	TOP PANEL	1		
16	S70 E95 641	TOP PANEL		1	
17	S70 E80 655	HANDLE	1	1	
18	S70 E15 631	ICE GUARD	1	1	

**STRUCTURAL PARTS**  
**PUZ-WM60VAA.UK**  
**PUZ-WM60VAA-BS.UK**

**PUZ-WM85VAA.UK**  
**PUZ-WM85VAA-BS.UK**

**PUZ-WM85YAA.UK**  
**PUZ-WM85YAA-BS.UK**

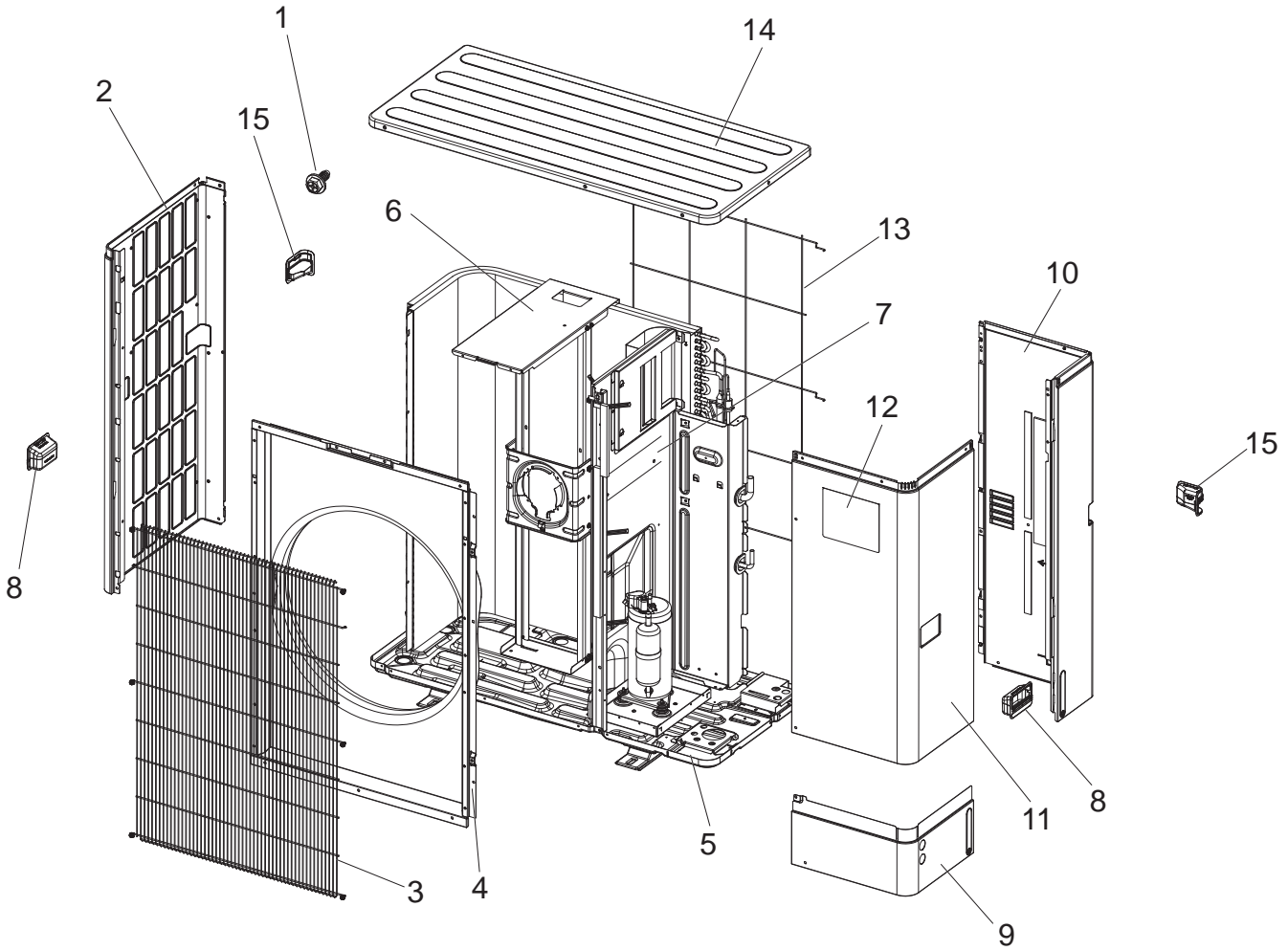

1. The part quantity below indicates the required number of pieces per unit.
2. The circled No. indicates that the part is not shown in the figure.

No.	Parts No.	Parts Name	PUZ-WM60VAA.UK	PUZ-WM60VAA-BS.UK	PUZ-WM85VAA.UK	PUZ-WM85VAA-BS.UK	PUZ-WM85YAA.UK	PUZ-WM85YAA-BS.UK	Remarks [Drawing No.]
1	—	F.ST SCREW	57	57	57	57	57	57	(5x12) [DG12F536H12-JP]
2	S70 E22 662	SIDE PANEL (L)	1		1		1		
2	S70 E23 662	SIDE PANEL (L)		1		1		1	
3	S70 E04 675	WIRE GRILLE	1	1	1	1	1	1	
4	S70 E73 668	FRONT PANEL	1		1		1		
4	S70 E74 668	FRONT PANEL		1		1		1	
5	S70 E54 686	BASE ASSY	1	1	1	1	1	1	
6	S70 E76 130	MOTOR SUPPORT	1		1		1		
6	S70 E77 130	MOTOR SUPPORT		1		1		1	
7	—	SEPARATOR	1		1				[BK00V807G17]
7	—	SEPARATOR					1		[BK00V807G29]
7	—	SEPARATOR		1		1			[BK00V807G18]
7	—	SEPARATOR						1	[BK00V807G30]
8	S70 E40 655	HANDLE (FRONT)	2	2	2	2	2	2	
9	S70 E75 658	COVER PANEL (FRONT)	1		1		1		
9	S70 E76 658	COVER PANEL (FRONT)		1		1		1	
10	S70 E75 662	SIDE PANEL(R)/COVER PANEL(R)	1		1		1		
10	S70 E76 662	SIDE PANEL(R)/COVER PANEL(R)		1		1		1	
11	S70 E91 661	SERVICE PANEL	1		1		1		
11	S70 E92 661	SERVICE PANEL		1		1		1	
12	S70 E55 699	BRAND LABEL (ECODAN)	1	1	1	1	1	1	
13	S70 E40 698	REAR GUARD	1	1	1	1	1	1	
14	S70 E70 641	TOP PANEL	1		1		1		
14	S70 E80 641	TOP PANEL		1		1		1	
15	S70 E50 655	HANDLE (REAR)	2	2	2	2	2	2	

**STRUCTURAL PARTS**  
**PUZ-WM112VAA.UK**  
**PUZ-WM112VAA-BS.UK**

**PUZ-WM112YAA.UK**  
**PUZ-WM112YAA-BS.UK**

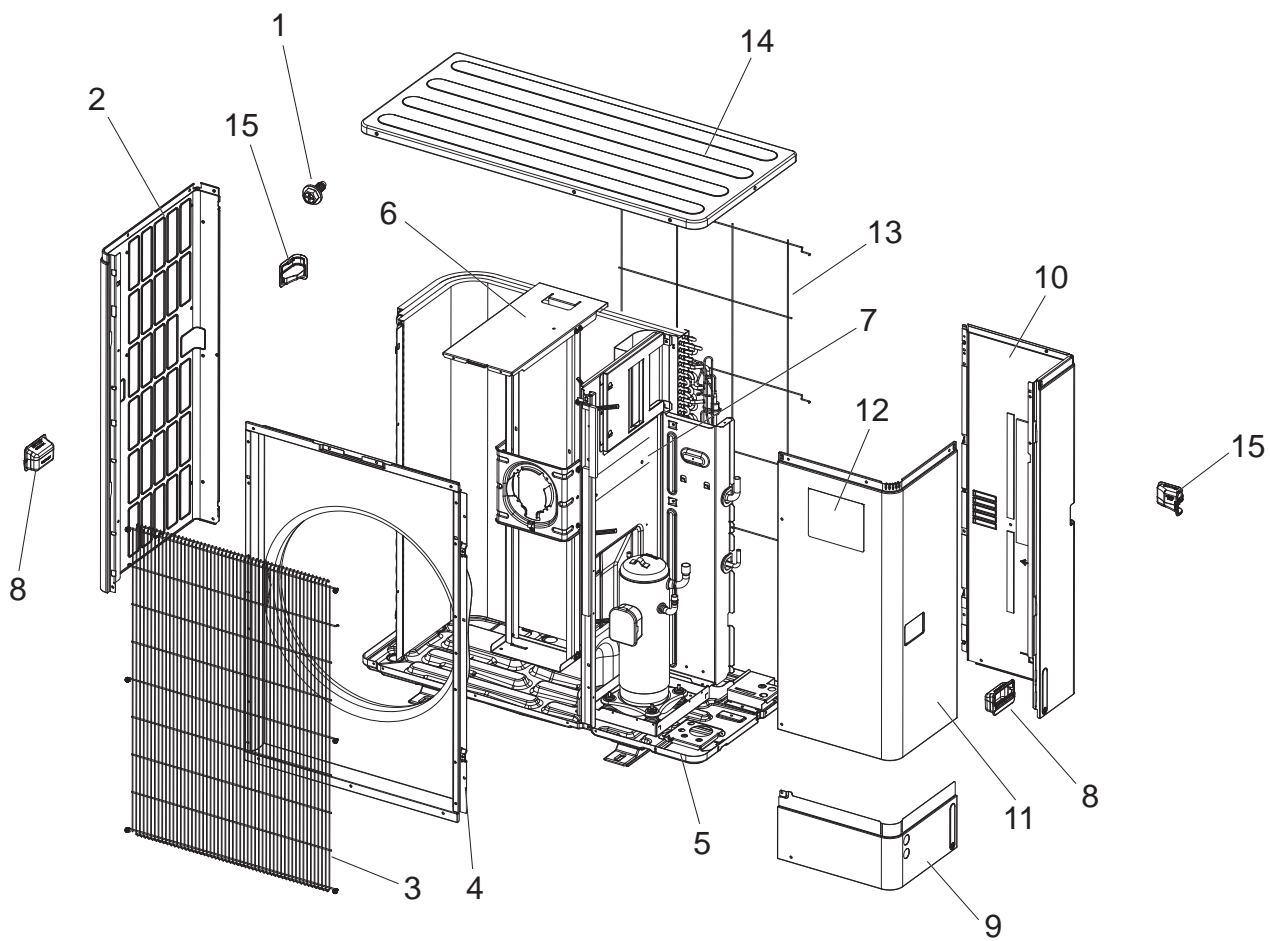





1. The part quantity below indicates the required number of pieces per unit.
2. The circled No. indicates that the part is not shown in the figure.

No.	Parts No.	Parts Name	PUZ-WM112VAA.UK	PUZ-WM112VAA-BS.UK	PUZ-WM112YAA.UK	PUZ-WM112YAA-BS.UK	Remarks [Drawing No.]
1	—	F.ST SCREW	57	57	57	57	(5x12) [DG12F536H12-JP]
2	S70 E22 662	SIDE PANEL (L)	1		1		
2	S70 E23 662	SIDE PANEL (L)		1		1	
3	S70 E04 675	WIRE GRILLE	1	1	1	1	
4	S70 E73 668	FRONT PANEL	1		1		
4	S70 E74 668	FRONT PANEL		1		1	
5	S70 E61 686	BASE ASSY	1	1	1	1	
6	S70 E78 130	MOTOR SUPPORT	1		1		
6	S70 E79 130	MOTOR SUPPORT		1		1	
7	—	SEPARATOR	1				[BK00V807G21]
7	—	SEPARATOR		1			[BK00V807G22]
7	—	SEPARATOR			1		[BK00V807G31]
7	—	SEPARATOR				1	[BK00V807G32]
8	S70 E40 655	HANDLE (FRONT)	2	2	2	2	
9	S70 E75 658	COVER PANEL (FRONT)	1		1		
9	S70 E76 658	COVER PANEL (FRONT)		1		1	
10	S70 E77 662	SIDE PANEL(R)/COVER PANEL (REAR)	1		1		
10	S70 E78 662	SIDE PANEL(R)/COVER PANEL (REAR)		1		1	
11	S70 E91 661	SERVICE PANEL	1		1		
11	S70 E92 661	SERVICE PANEL		1		1	
12	S70 E55 699	BRAND LABEL (ECODAN)	1	1	1	1	
13	S70 E40 698	REAR GUARD	1	1	1	1	
14	S70 E70 641	TOP PANEL	1		1		
14	S70 E80 641	TOP PANEL		1		1	
15	S70 E50 655	HANDLE (REAR)	2	2	2	2	

## CONNECTOR FOR DRAIN HOSE SIGNAL OUTPUT

Parts No.	PAC-SE60RA-E
-----------	--------------

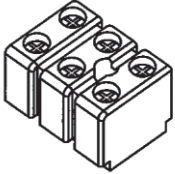
## Contents

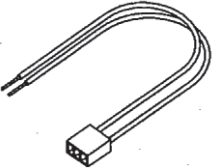
① Terminal block	×1
	
② Screw	×1
	
③ Lead wire with connector	×1
	

## Installation

## ● PUZ-WM50VHA(-BS) models

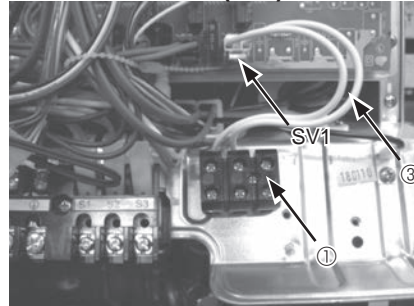

## ● PUZ-\*\*\*VAA models

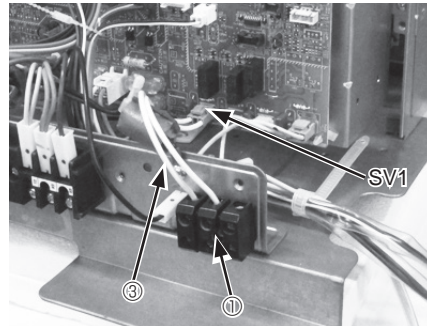

## ● PUZ-\*\*\*YAA models

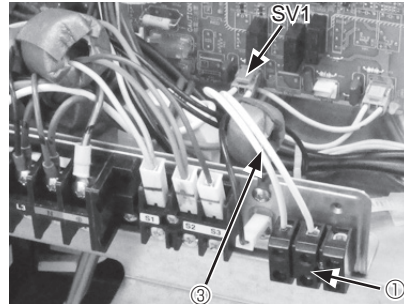

1. Attach the terminal block ①, with the screw ②.
2. Connect the lead wire ③ connector side to SV1 port on the outdoor controller board.
3. Connect the lead wire ③ to the terminal block ①.
4. Wire local cables for a drain hose heater RELAY to the terminal block ①.

- Drain hose heater RELAY connection only
- MAX current 1A

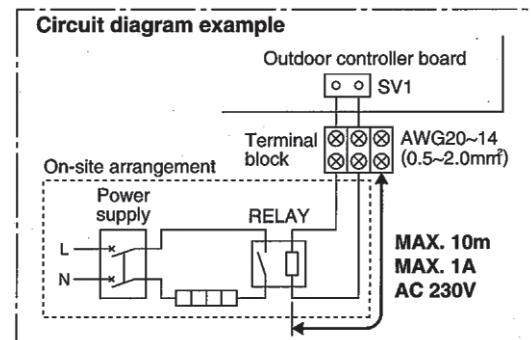

SV1 on the controller board  
→ Drain hose heater signal output  
With PAC-SE60RA-E  
From defrost start  
For 15 min ON signal provided

## AIR DISCHARGE GUIDE

Parts No.	PAC-SG59SG-E(PUZ-WM50VHA(-BS), PAC-SH96SG-E(PUZ-WM60/85/112VAA(-BS), PUZ-WM60/85/112YAA(-BS))
-----------	--

## AIR PROTECTION GUIDE

Parts No.	PAC-SH63AG-E(PUZ-WM50VHA(-BS)), PAC-SH95AG-E(PUZ-WM60/85/112VAA(-BS),PUZ-WM60/85/112YAA(-BS))
-----------	--

## ATTACHMENT (AIR DISCHARGE GUIDE/AIR PROTECTION GUIDE)

Parts No.	PAC-SJ82AT-E (PUZ-WM60/85/112VAA(-BS),PUZ-WM60/85/112YAA(-BS))
-----------	--

## DRAIN SOCKET

Parts No.	PAC-SG61DS-E
-----------	--------------

## CENTRALIZED DRAIN PAN

Parts No.	PAC-SG64DP-E (PUZ-WM50VHA)
	PAC-SJ83DP-E (PUZ-WM60/85/112VAA(-BS),PUZ-WM60/85/112YAA(-BS))



# **mitsubishi electric corporation**

HEAD OFFICE : TOKYO BUILDING, 2-7-3, MARUNOUCHI, CHIYODA-KU, TOKYO 100-8310, JAPAN

---